

PRO4 SC10

1:10 Scale Ready-To-Run 4WD
Electric Off Road Short Course Truck



INCLUDES
LED
FOUR PIECE LIGHT SET

**BRUSHLESS
POWERED
READY-TO-RUN**

#20531 PRO4 SC10 GENERAL TIRE GT™ Ready-To-Run



GENERAL TIRE

1:10 Scale Ready-To-Run 4WD Electric Off Road Short Course Truck Manual & Catalog



CHAMPIONS by DESIGN

AssociatedElectrics.com

TEAM ASSOCIATED

:: Introduction

Thank you for purchasing this Team Associated product. This assembly manual contains instructions and tips for building and maintaining your new vehicle. Please take a moment to read through the manual and familiarize yourself with the steps. We are continually changing and improving our designs; therefore, actual parts may appear slightly different than the illustrations. New parts will be noted on supplementary sheets located in the appropriate parts bags. Check each bag for these sheets before you start to build.

:: Pro4 SC10 RTR Features

- 2.4GHz 2-channel radio system
- High-Torque Digital Servo with spring-style servo saver
- Powerful Reedy 3300kV Brushless Motor
- Water-resistant high-power Reedy brushless speed control with T-plug connector and LiPo low-voltage cutoff
- Three sealed gear differentials
- Fifteen 52 Turbomac HD wheels
- Threaded Oil-filled coil over shock absorbers
- 4mm heavy-duty adjustable alloy steel turnbuckles
- Durable slider type drive shafts
- Factory-finished Contender short course body
- High-grip General Tire GT(R) Grabber all terrain tires
- Steel center drive shaft
- Four-wheel independent suspension
- Durable, impact-absorbing front and rear bumpers with LEDs

:: Table of Contents

1..... Cover	6 - 19.....Steps 1- 41
2..... Introduction	20.....Tuning Tips
3.....1:1 Hardware "Fold Out"	21 - 29..... Catalog/Notes
4 - 5..... Quick Start Guide	30..... Back Cover

:: Notes



There is a 1:1 hardware foldout page in the front of the manual. To check the size of a part, line up your hardware with the correct drawing until you find the exact size. Each part in the foldout has a number assigned to it for ordering replacement parts.



This symbol indicates a special note or instruction in the manual.

:: Additional

Your new Pro4 SC10 comes assembled. The following items are needed for completion.

- 6-cell NiMh or 2-3s LiPo battery
- Suitable battery charger
- (4) AA batteries

Tools included: • 1.5mm, 2.0mm, 2.5mm Wrenches

:: Other Helpful Items

- Silicone Shock Fluid (Refer to catalog for complete listings)
- Silicone Diff Fluid (Refer to catalog for complete listings)
- Body Scissors (AE Part # 1737)
- Reamer / Hole Punch (#1499)
- Shock Pliers (#1675)
- Wire Cutters
- FT Hex/Nut Wrenches (AE Part # 1650)
- Needle Nose Pliers
- Hobby Knife
- Soldering Iron
- Calipers or a Precision Ruler
- Green Slime shock lube (AE Part # 1105)
- FT Turnbuckle Wrench (#1114)
- FT Universal Tire Balancer (#1498)













Associated Electrics, Inc.
21062 Bake Pkwy.
Lake Forest, CA 92630



Customer Service
Tel: 949.544.7500
Fax: 949.544.7501

:: Hardware - 1:1 Scale View







Button Head (bhcs)

	2.5x5mm (31519)
	2.5x6mm (31520)
	3x4mm (91158)
	3x6mm (31531)
	3x8mm (31532)
	3x10mm (25211) Aluminum (8554) Titanium (91582)
	3x12mm (89202) Titanium (91583)
	3x14mm (25187) Titanium (91584)
	3x16mm (89203) Titanium (91585)
	3x18mm (2308)
	3x20mm (25188) Titanium (91587)
	3x22mm (25189) Titanium (91588)
	4x10mm (89206)



Socket Head (shcs)

	2.5x6mm (41079)
--	------------------------





Flat Head (fhcs)

	2.5x8mm (31448)
	2.5x10mm (31350)
	3x6mm (31541)
	3x12mm (25203) Aluminum (8556) Titanium (91594)
	3x14mm (89208) Aluminum (8567) Titanium (91595)
	3x18mm (89209) Titanium (91597)
	4x10mm (81262)





Set Screws

	3x3mm (25225)
	3x12mm (81258)
	4x12mm (25824)







Shims and Washers

	5.5x0.5mm (31381)
	5.5x1.0mm (31382)
	5.5x2.0mm (31383)
	3x8mm Washer (89218)

Ball Bearings

	5x8x2.5mm (8680)
	5x11x4mm (25618)
	10x15x4mm (91563)
	8x16x5mm (91564)
	12x18x4mm (25843)

Nuts (lock/plain)

	Plain M3 Nut (91477)
	M3 Alum. Locknut, Blue (31550)
	M3 Locknut, Black (25215)
	M4 Locknuts: Serrated Steel (Silver)(91826)
	FT Aluminum (Blue) (31551)
	Serrated Aluminum (Black) (91738)

Notes:

:: Quick Start Guide

Battery Charging Steps and Safety:

Remove the battery from the vehicle before charging.
Place battery on a fire resistant surface.
Avoid any contact with water or other liquids.
Be sure to select the correct charging mode for the type of battery you are charging.

ALWAYS use a compatible charger for charging your batteries.

Caution: Never leave the battery unattended while charging. Always disconnect the charger from the power source when finished charging.

Caution: Always disconnect the battery when you are finished driving the vehicle.



**Peak Detection
Quick Charger**

:: Quick Start Guide - (cont.)

Battery Installation:

1. Install the battery with the battery wires directed towards the rear of the vehicle.
2. Secure the battery strap using two hook and loop straps.

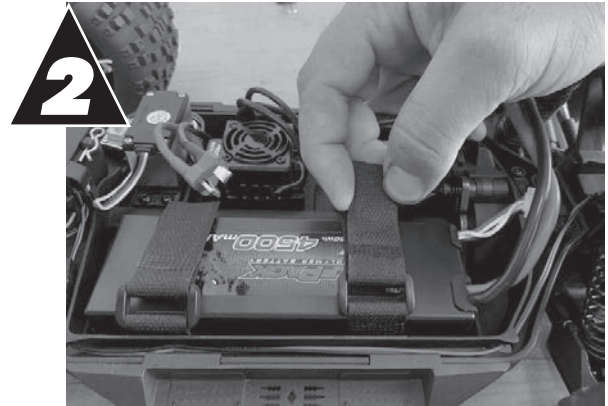
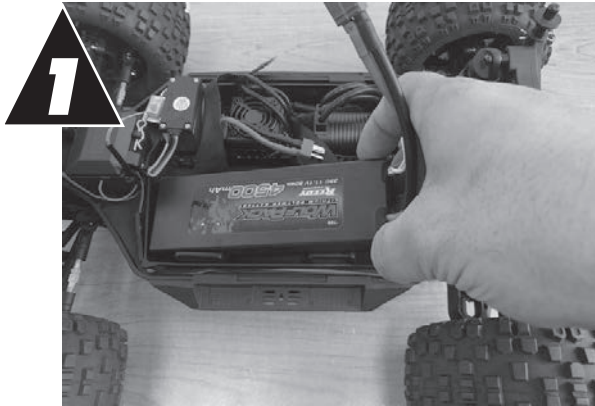

:: Quick Start Guide - (cont.)

Battery Notes and Tip:

Connect the battery as shown.
Disconnect the battery when not in use!

LiPo: LiPo batteries (lithium polymer) are high current rechargeable batteries. LiPo batteries offer extended run time and peak performance over NiMH batteries. They require a peak detection charger designed specifically for LiPo batteries. These batteries require special care and handling. LiPo batteries are recommended for advanced users only!
ALWAYS charge a LiPo battery in LiPo mode.

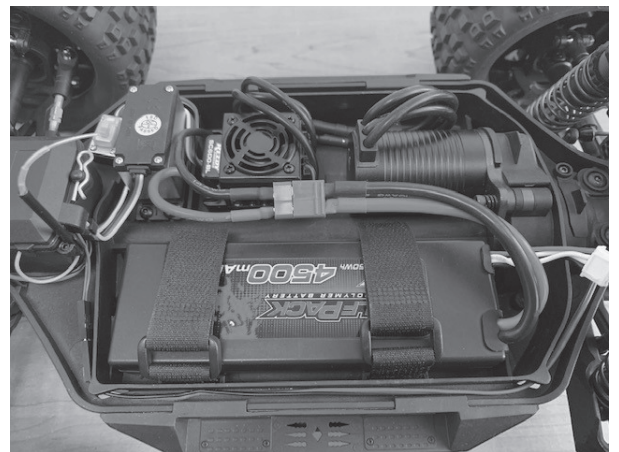

:: Quick Start Guide - (cont.)

Radio System Tuning and Controls:

RULE: Transmitter on First/Vehicle on Second,
Vehicle off First/ Transmitter off Last!

- 1) Slide the battery cover to remove cover.
- 2) Install alkaline or rechargeable AA size batteries into the battery holder.
- 3) Slide the battery cover back into place making sure it is completely closed and secure.
- 4) Turn the power ON. If the power indicator LED fails to light, check the batteries for insufficient contact or incorrect polarity.



On/Off Switch

:: Quick Start Guide - (cont.)

Radio System Tuning and Controls:

DO NOT hold the trigger when turning on the radio.

Refer to Radio owners manual for more in-depth instructions on radio operation and functions.

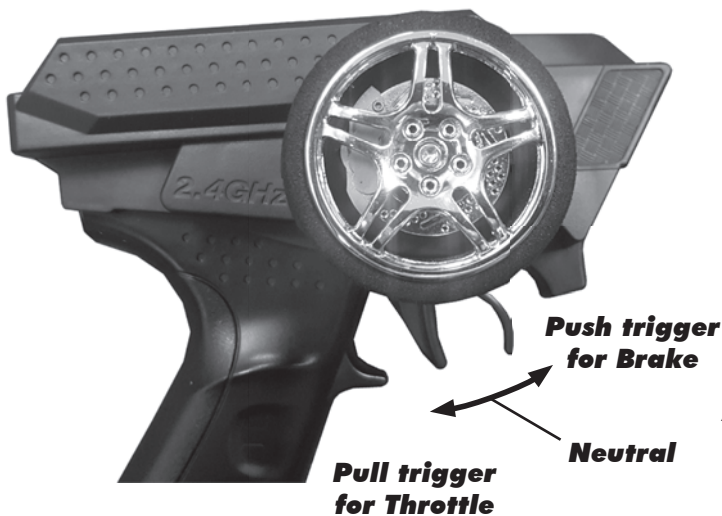

Throttle set to Neutral!



Adjust steering trim so front wheels point straight.

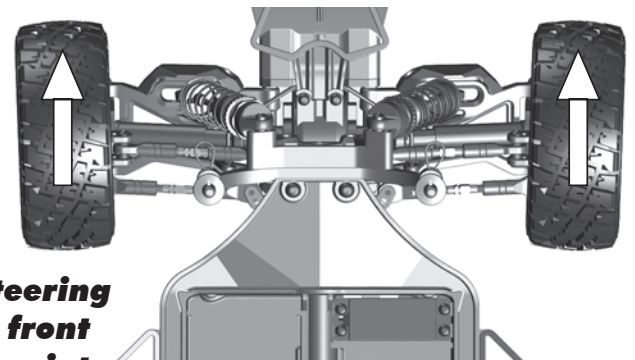

**Install body and body clips.
Ready to go!**

:: Step 1

25810 Sun Gear Shim

25810 Diff O-Ring

25810 Diff Output Shaft

25807 Diff Case (Front/Rear)

25810 Sun Gear Shim

25810 Diff O-Ring

25810 Diff Output Shaft

25810 Sun Gear

25810 Input Pin

25810 Sun Gear

25810 Input Pin

25808 Ring Gear, 37T

Build 2 (1 front, 1 rear)

:: Step 2

25810 $\times 4$ Planetary Gear

25810 $\times 2$ Diff Cross Pin

25810 $\times 4$ Planetary Gear Shim

25808 Diff Gasket

91563 $\times 2$ 10x15x4mm Bearing

31350 $\times 4$ 2.5x10mm FHCS

diff fluid

Front Diff Fluid: 60k cst #5458

Rear Diff Fluid: 3k cst #5452

:: Step 3

25812 Sun Gear Shim

25807 Diff Case (Center)

25812 Diff O-Ring

25812 Center Diff Shaft

25812 Sun Gear Shim

25811 Spur Gear (54T, 32P)

91564 8x16x5mm Bearing

25812 Center Diff Outdrive

25812 Center Diff Sun Gear

25812 Input Pin

25812 Center Diff Sun Gear

25812 Input Pin

25812 Diff O-Ring

Build 1 (1 center)

:: Step 4

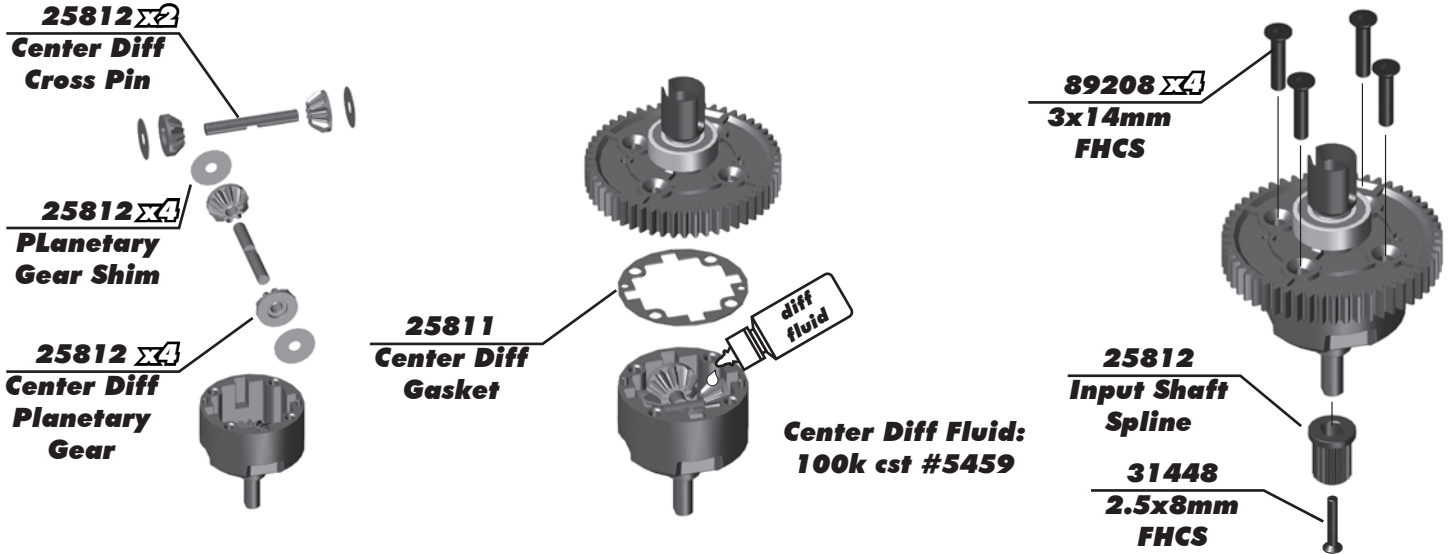

:: Step 5

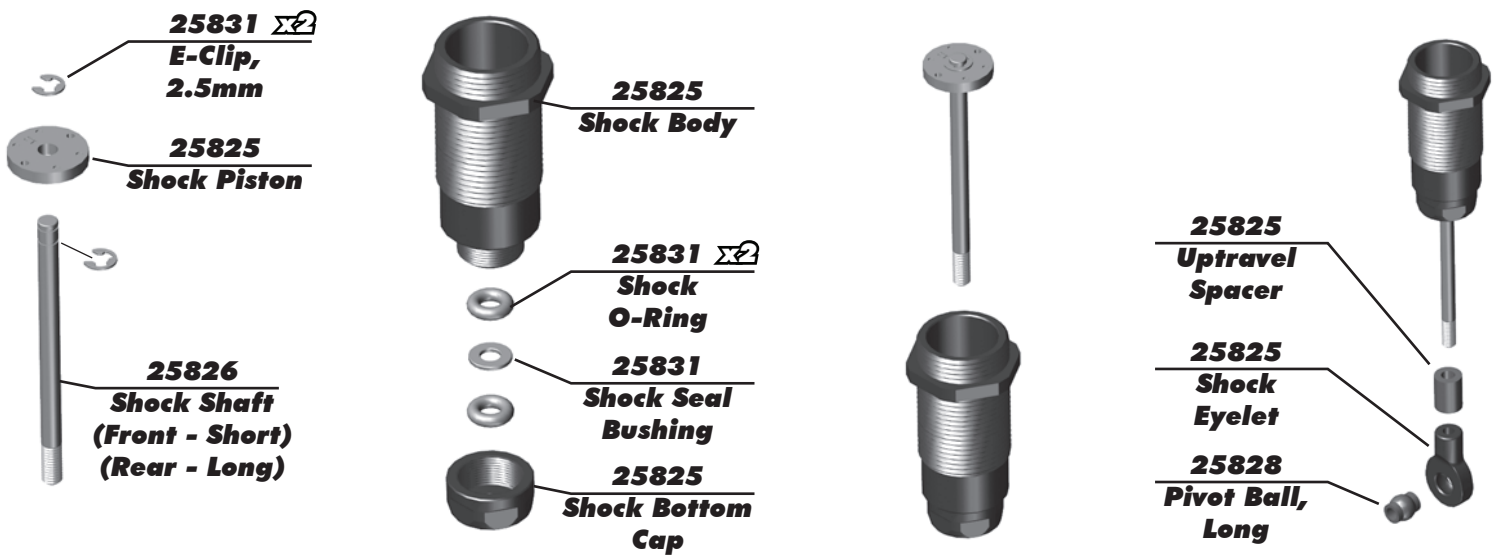

:: Step 6

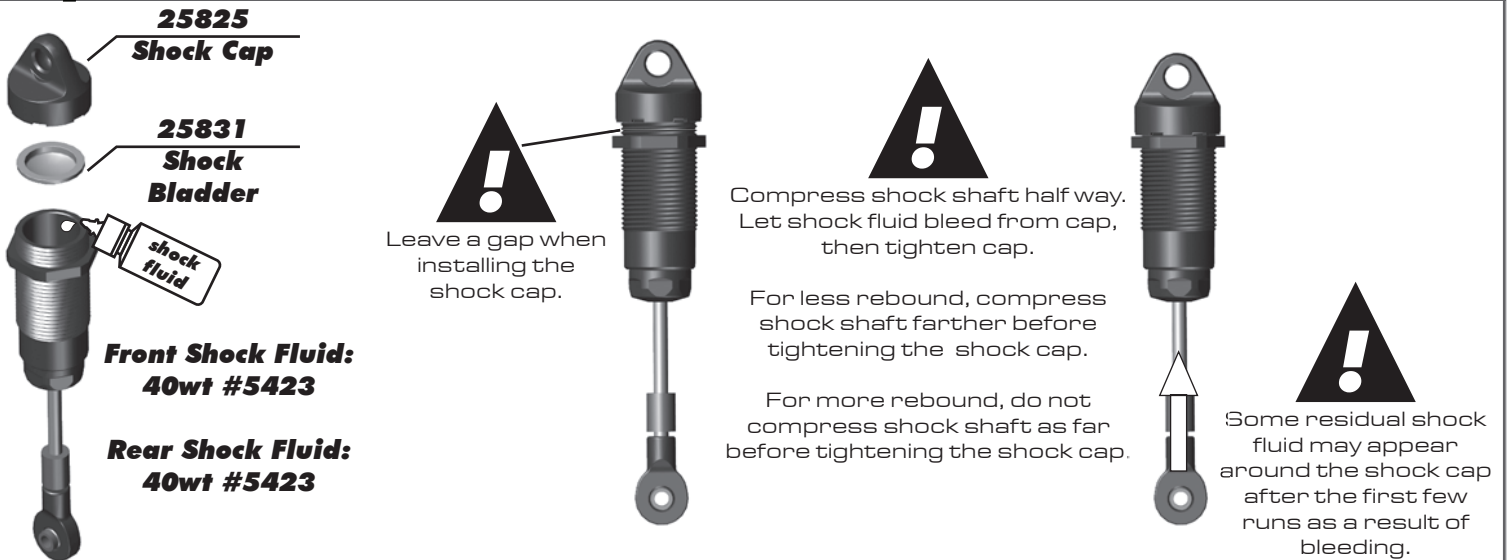

:: Step 7

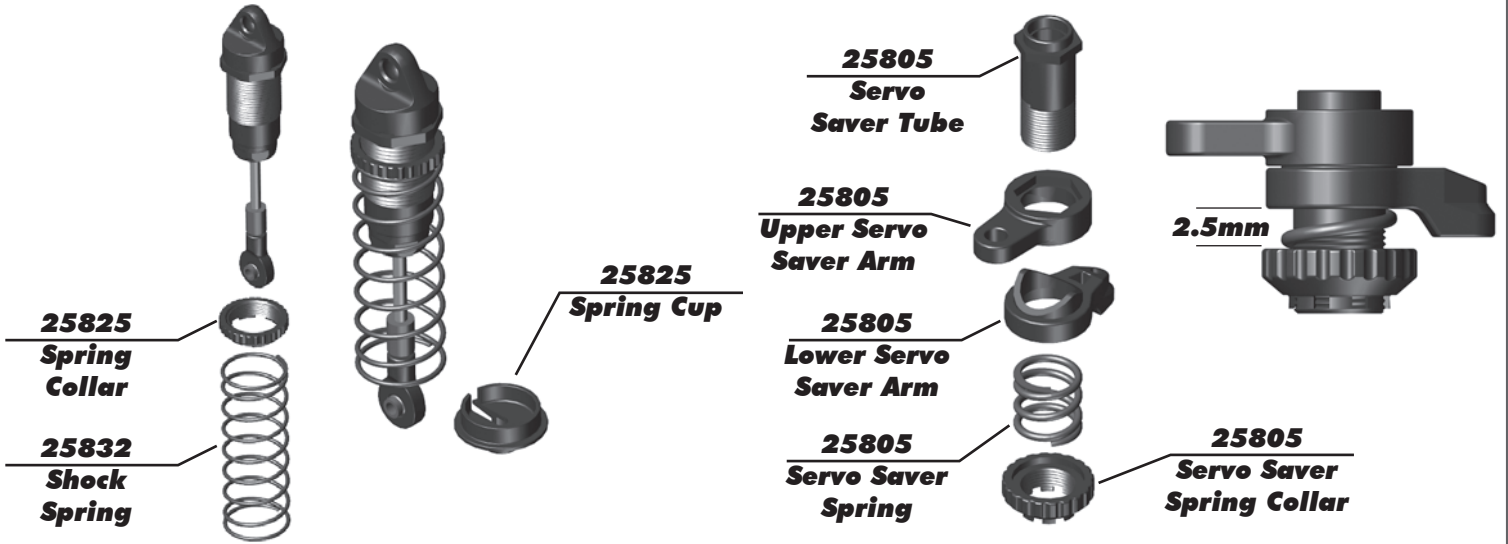

:: Step 8

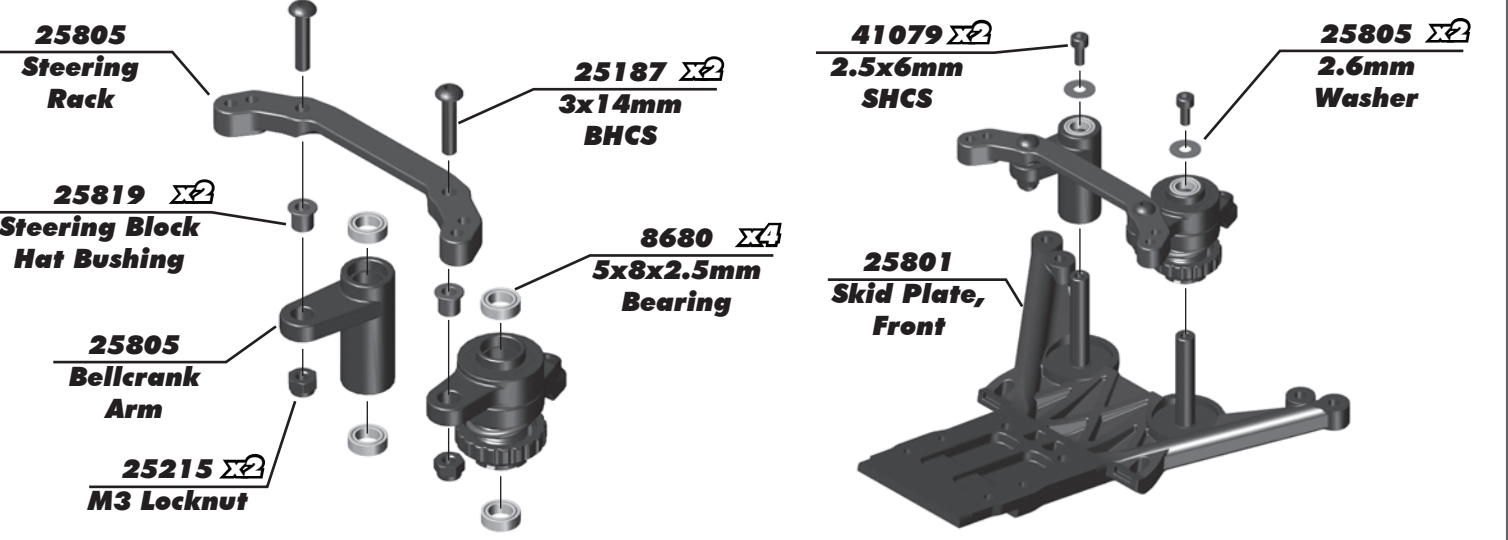

:: Step 9

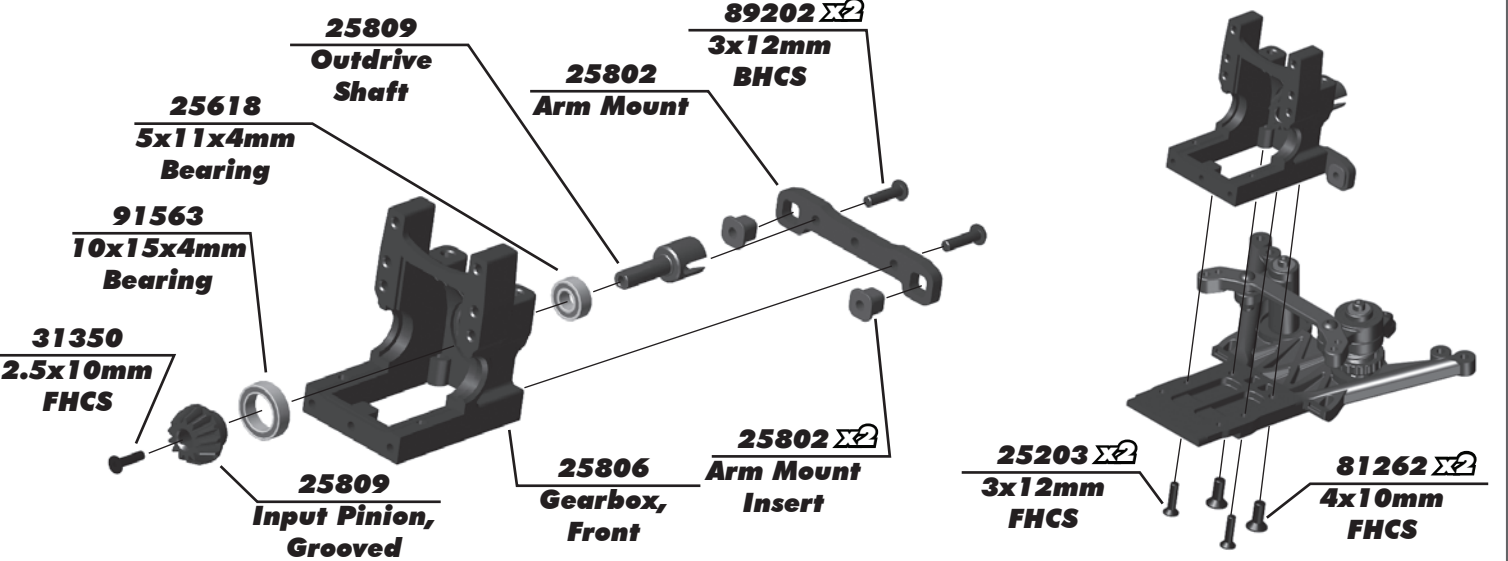

:: Step 10

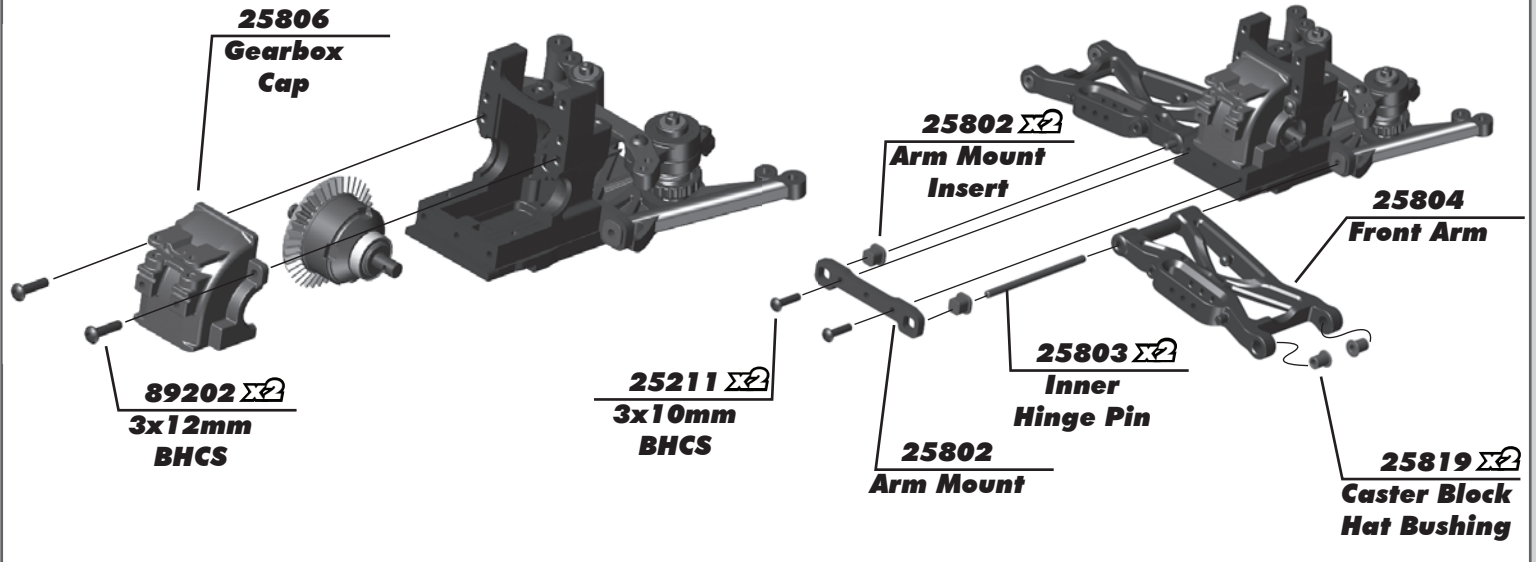

:: Step 11

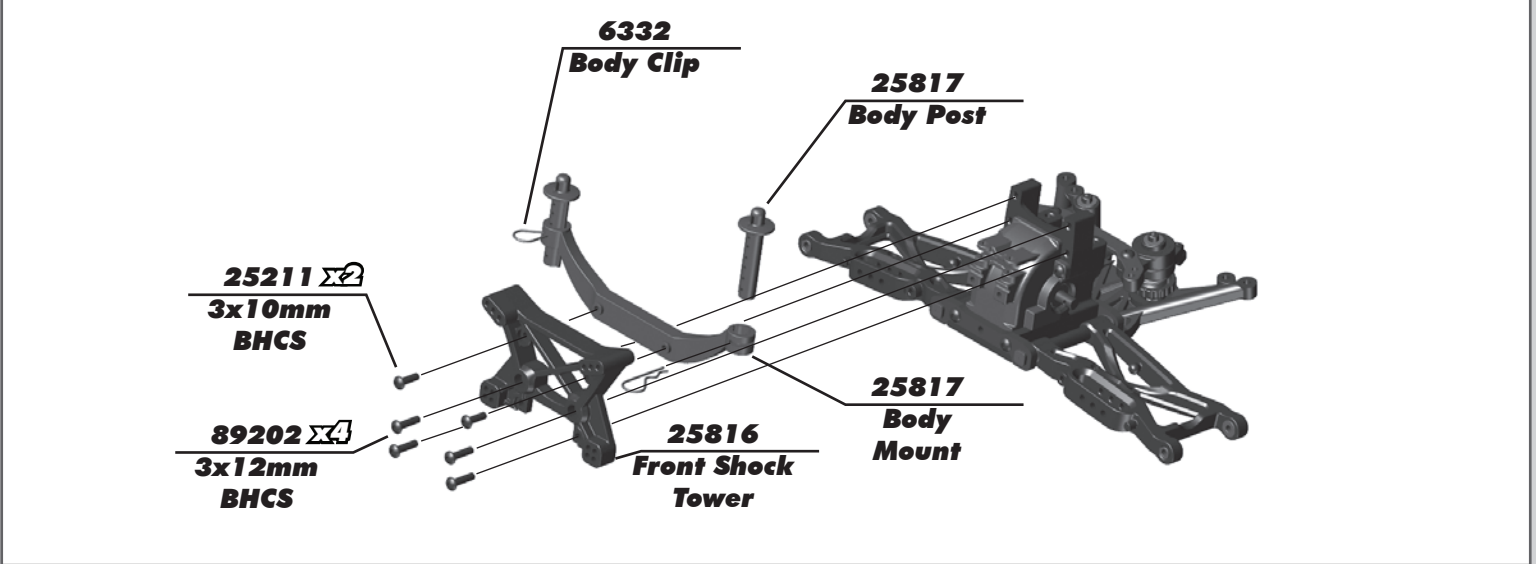

:: Step 12

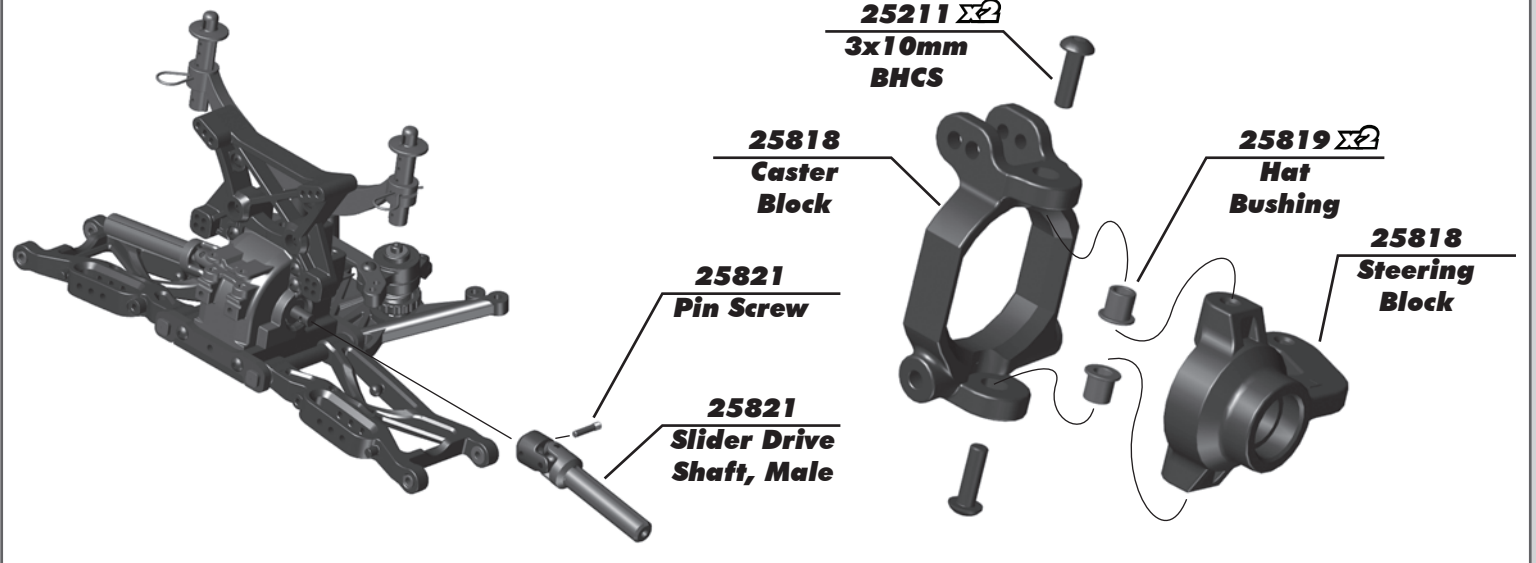

:: Step 13

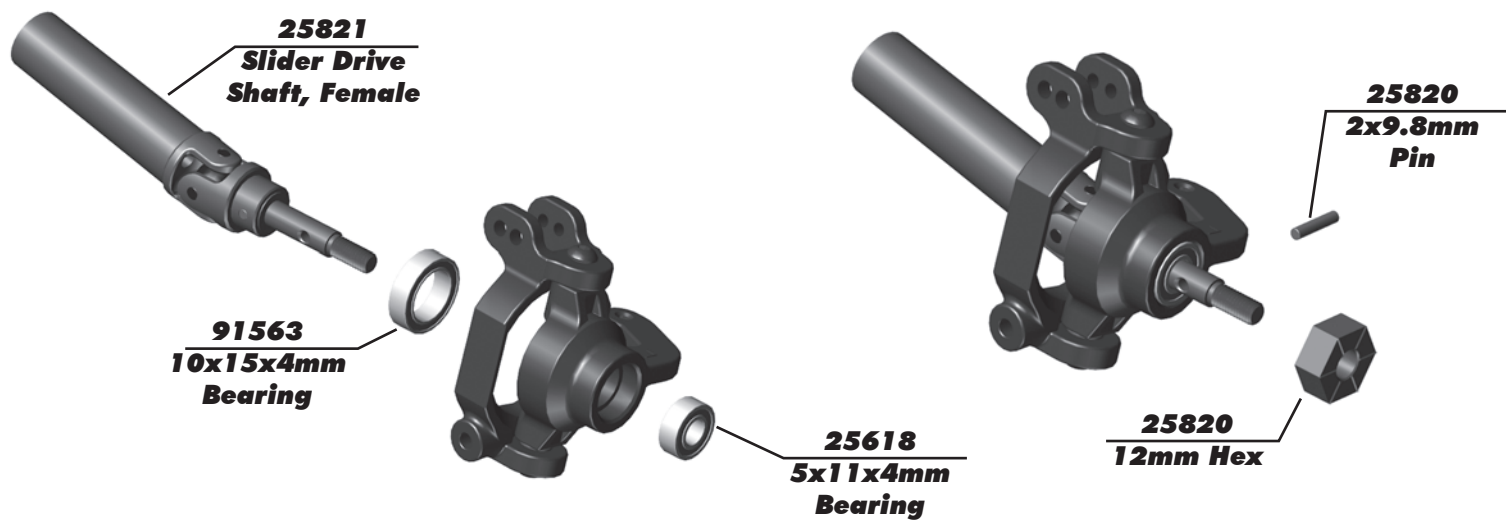

:: Step 14

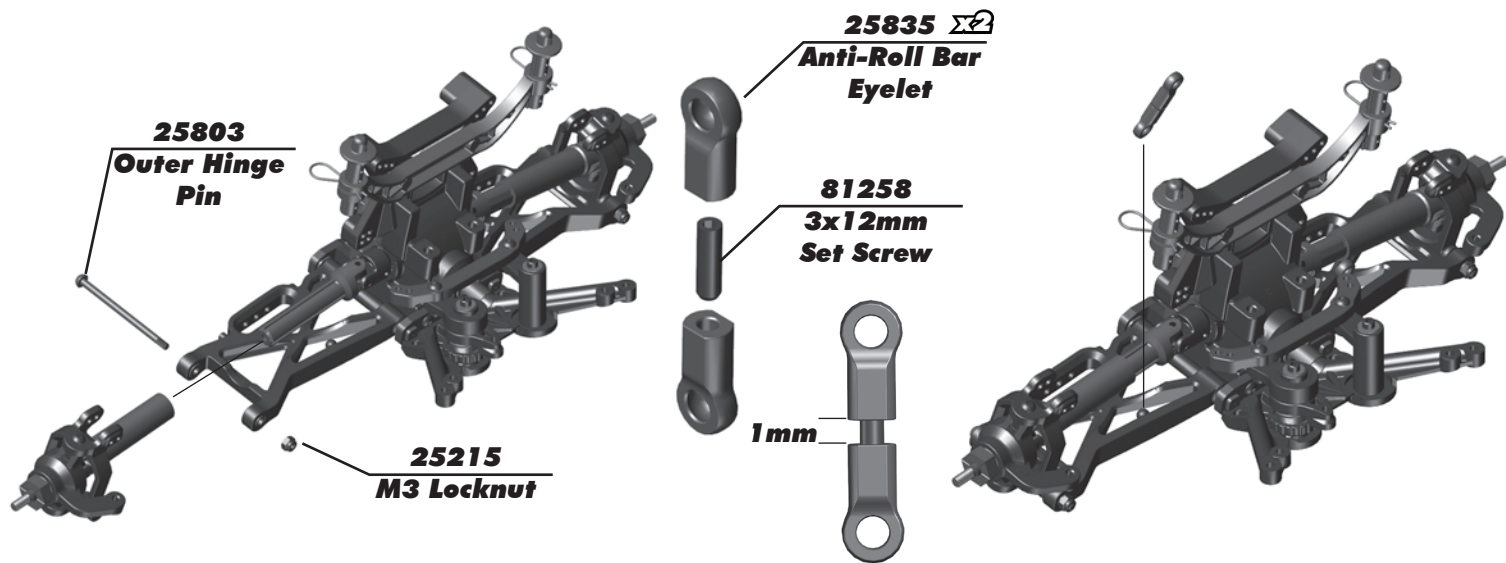

:: Step 15

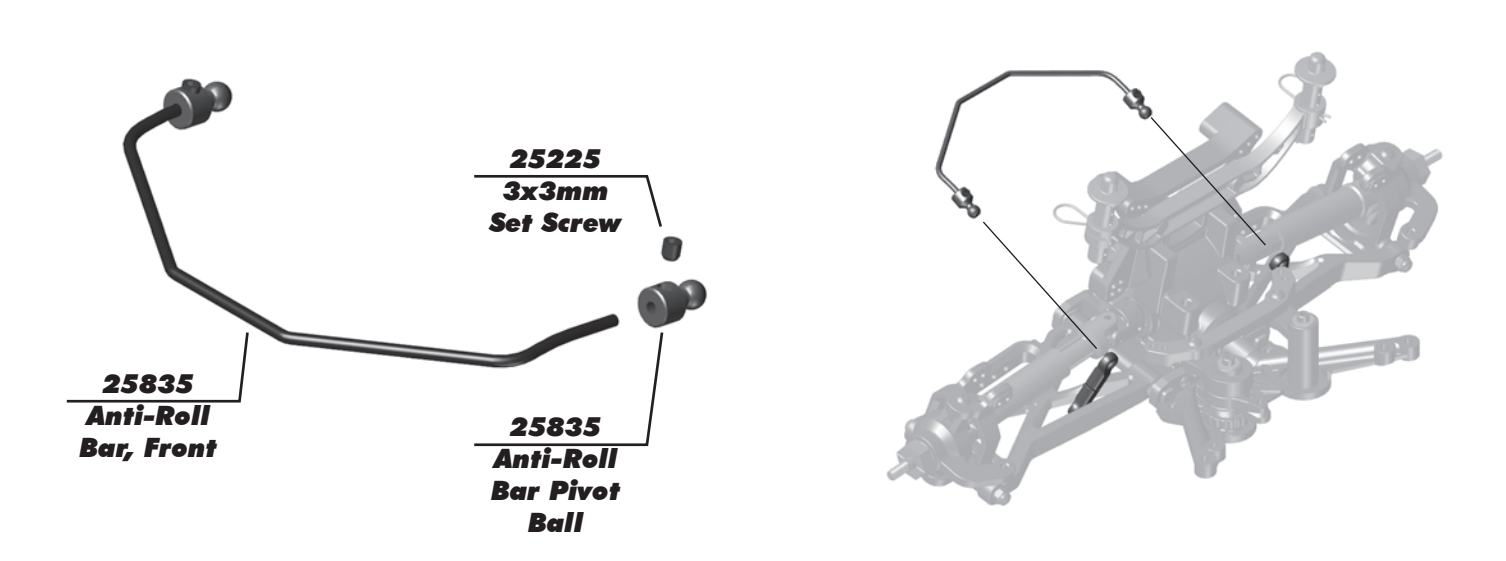

:: Step 16

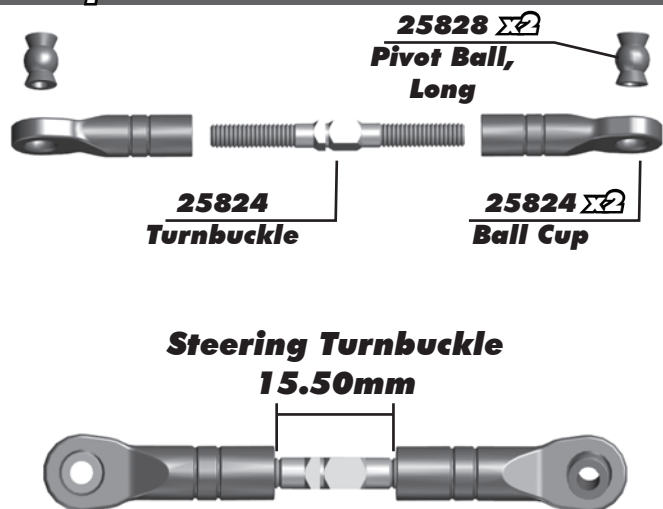

Build x2 (right and left side)

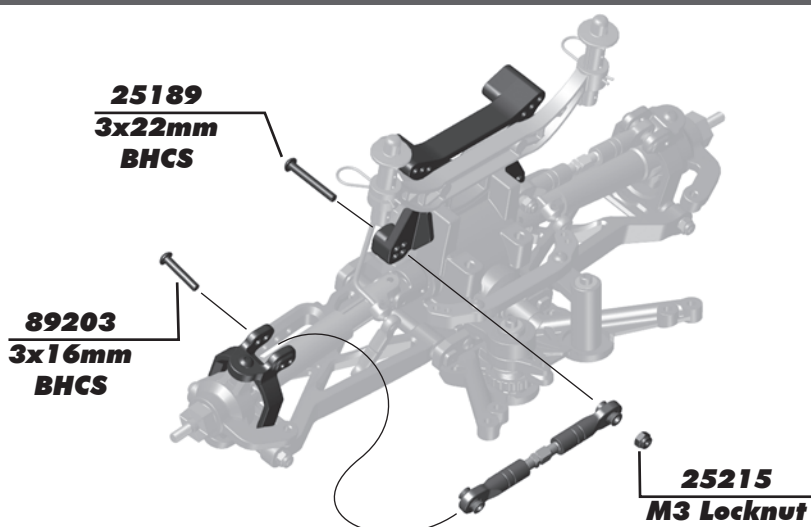

:: Step 17

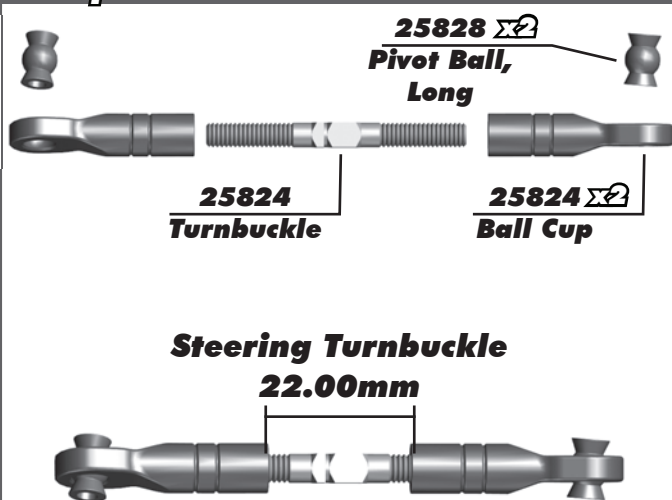

Build x2 (right and left side)

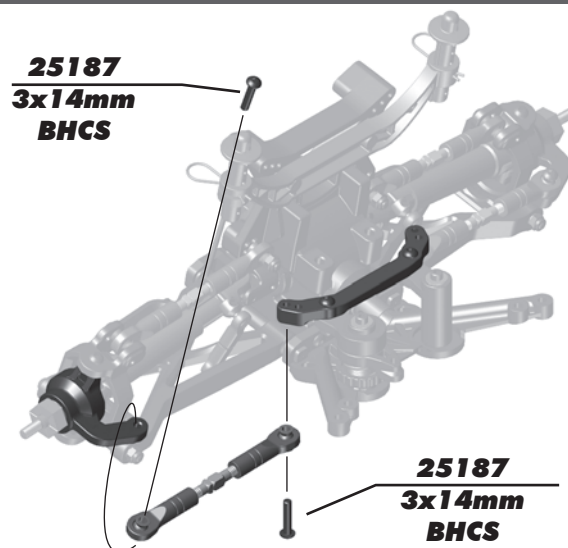

:: Step 18

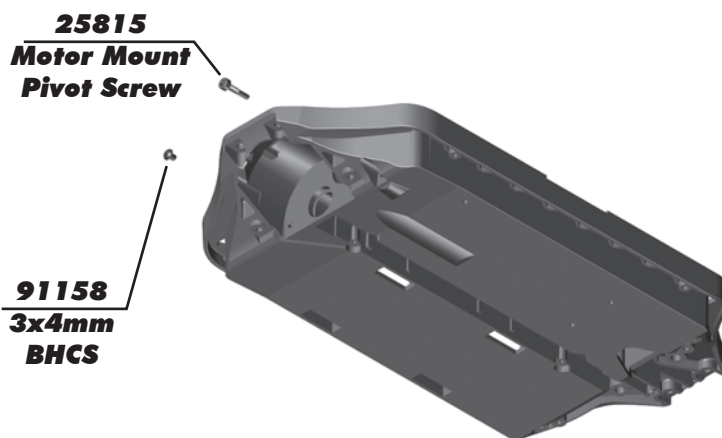
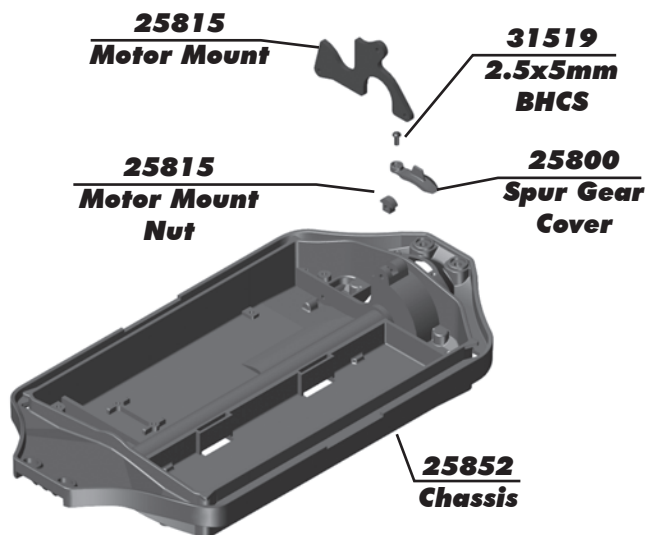

:: Step 19

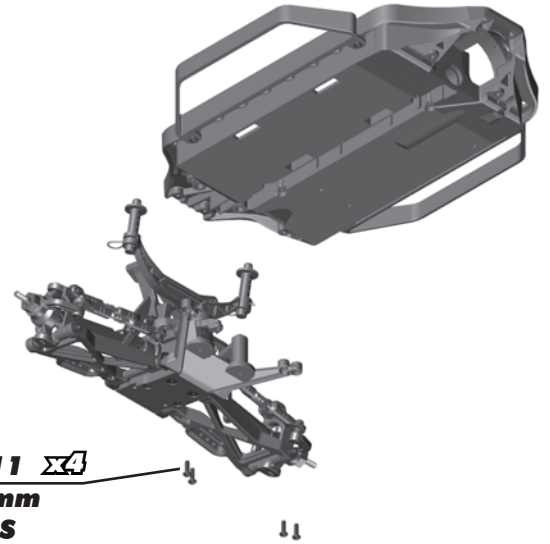
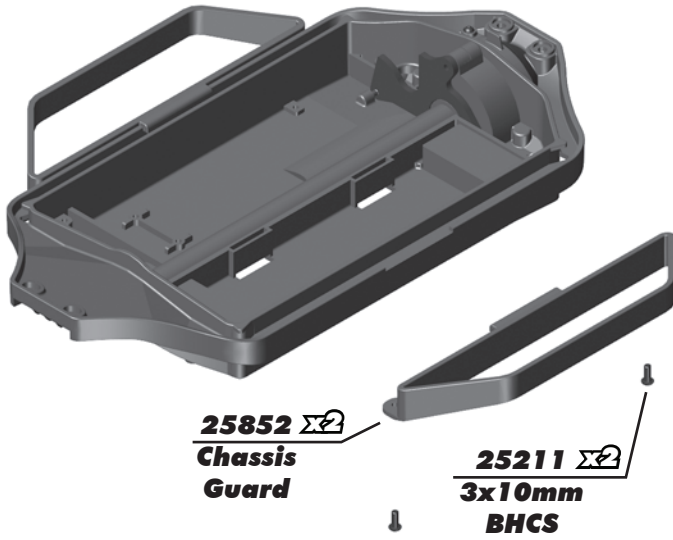

:: Step 20

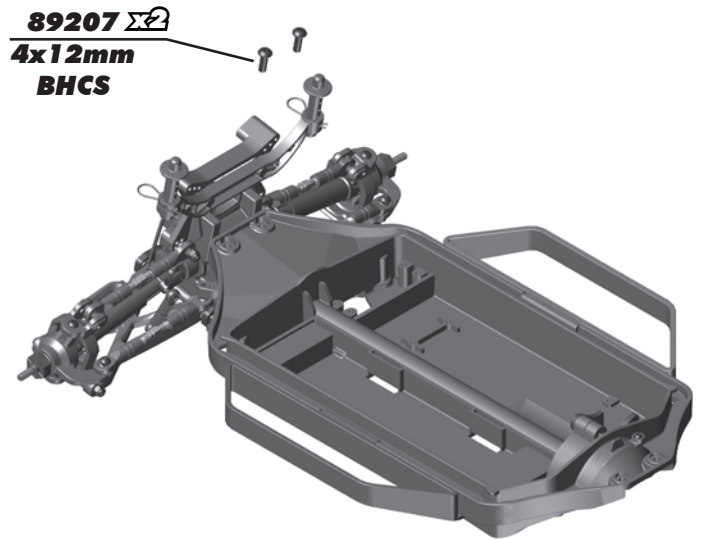
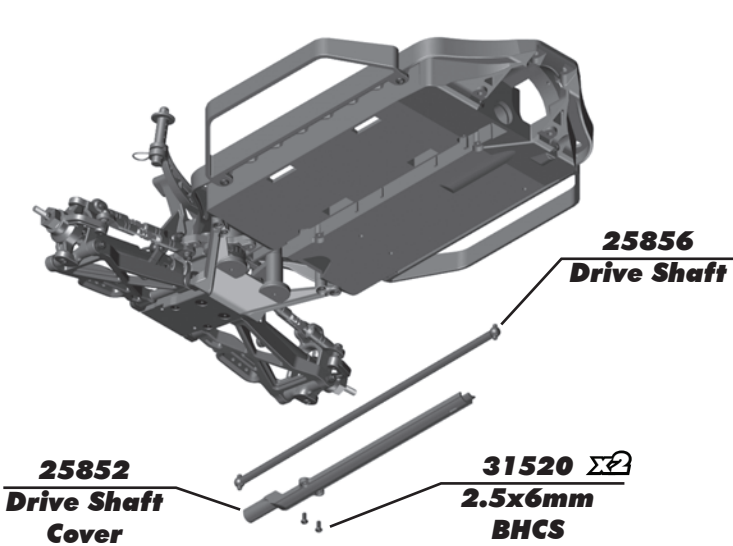

:: Step 21

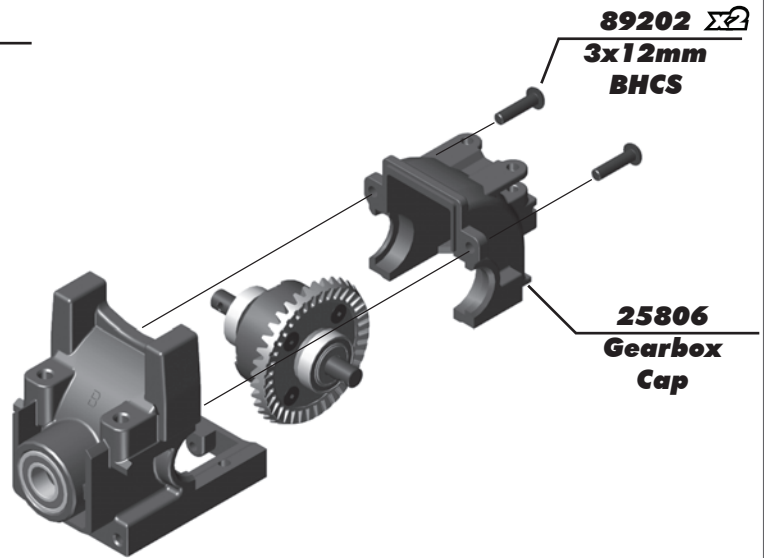
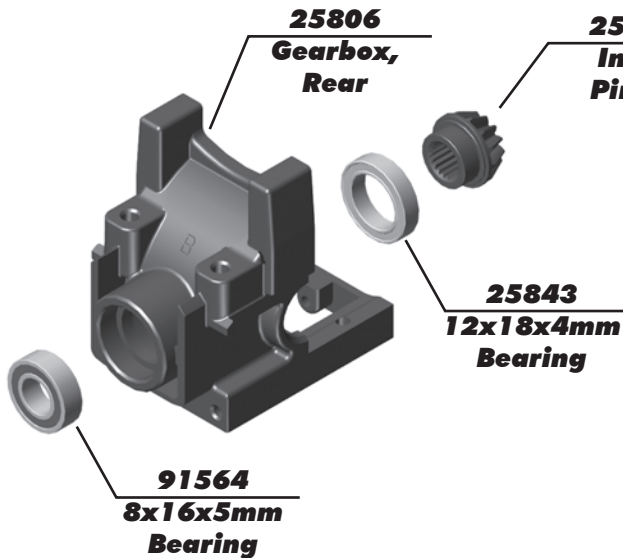

:: Step 22

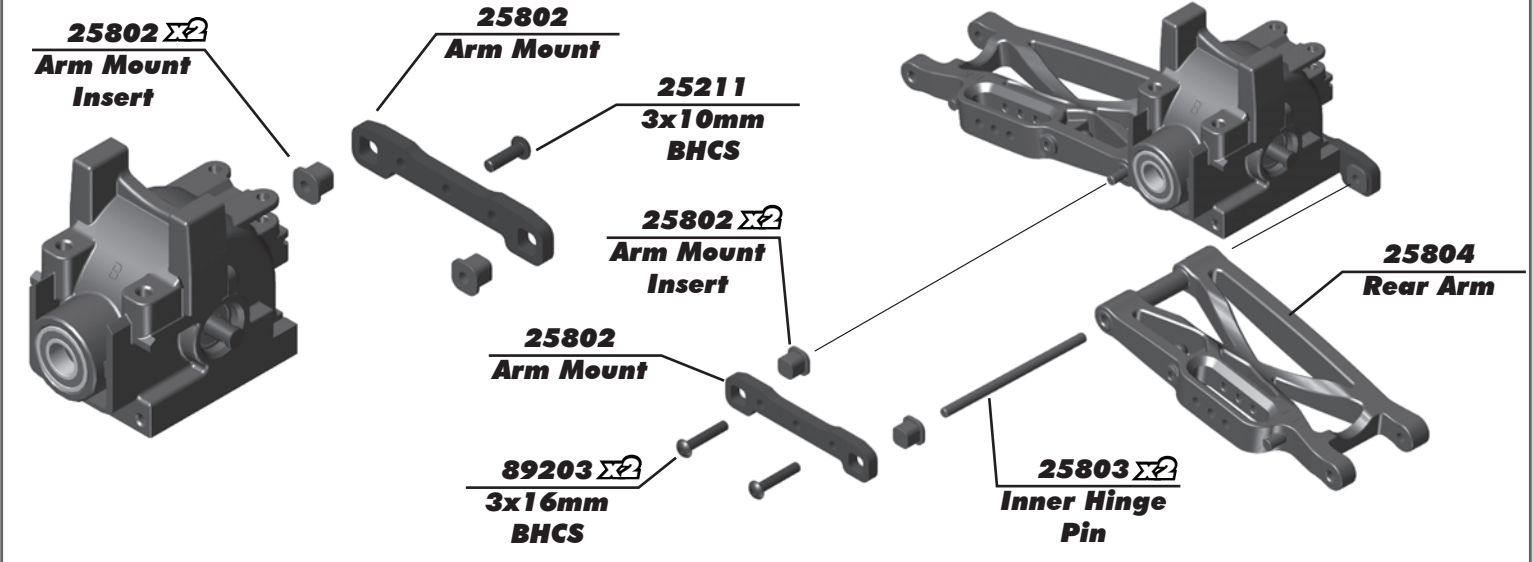

:: Step 23

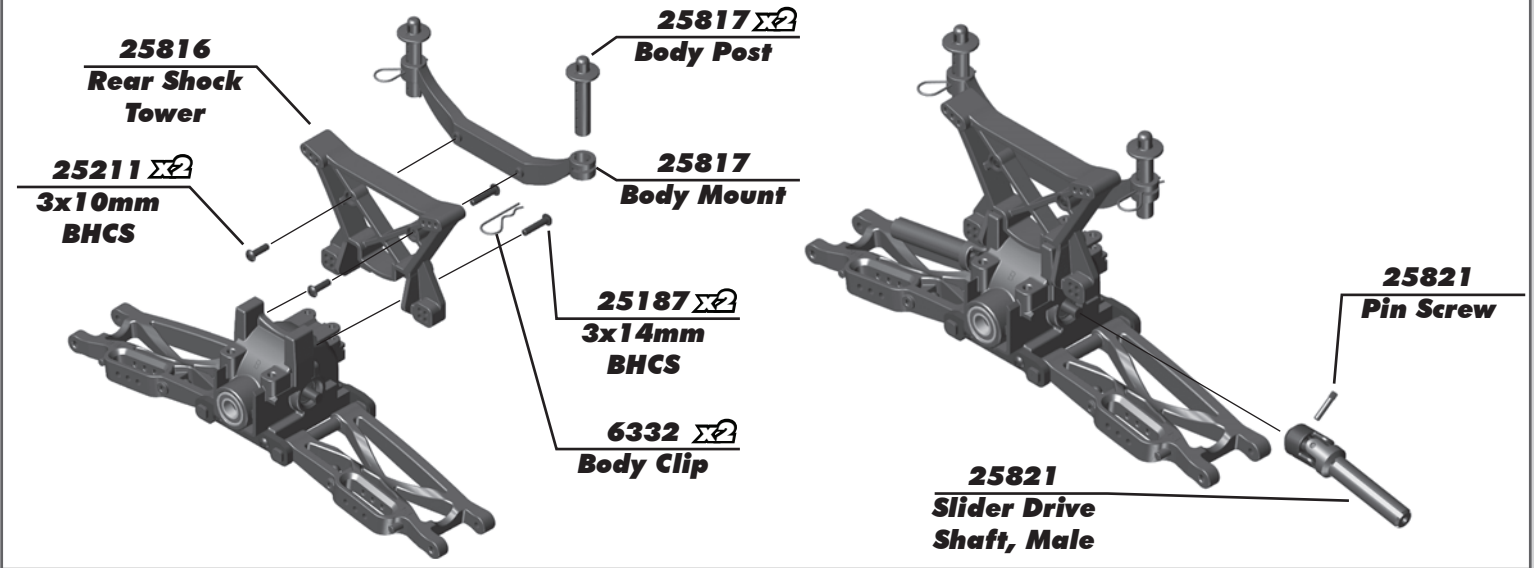

:: Step 24

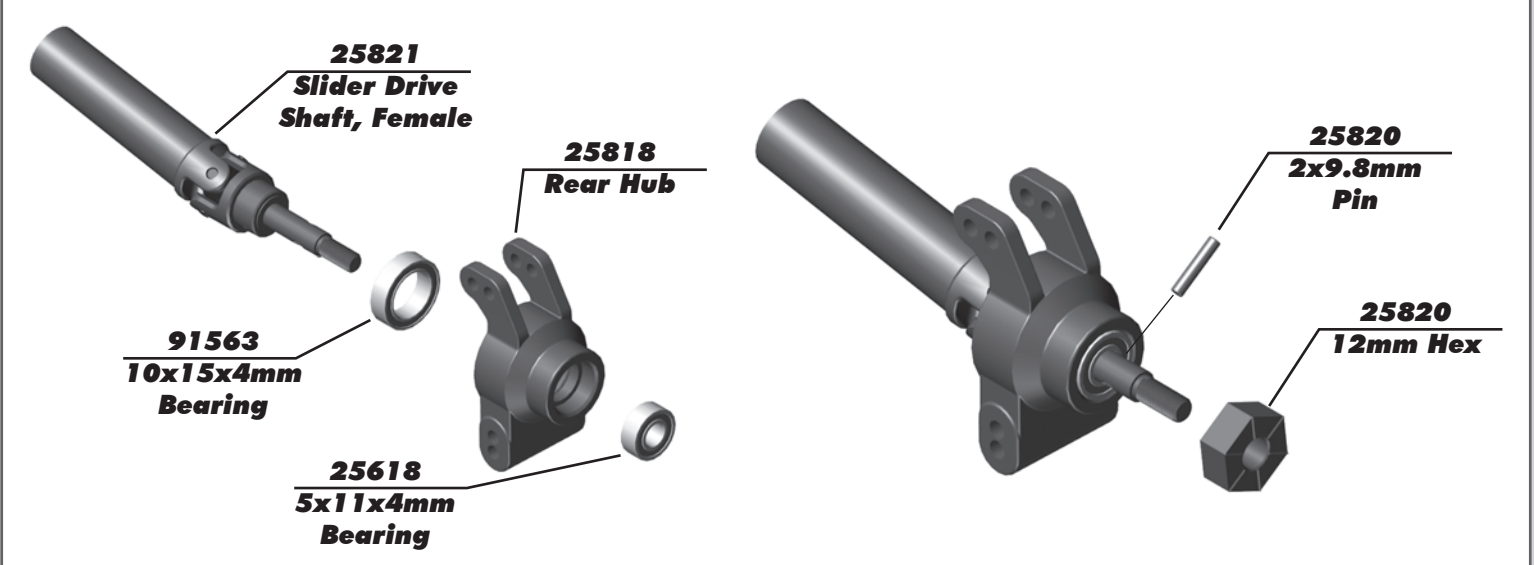

:: Step 25

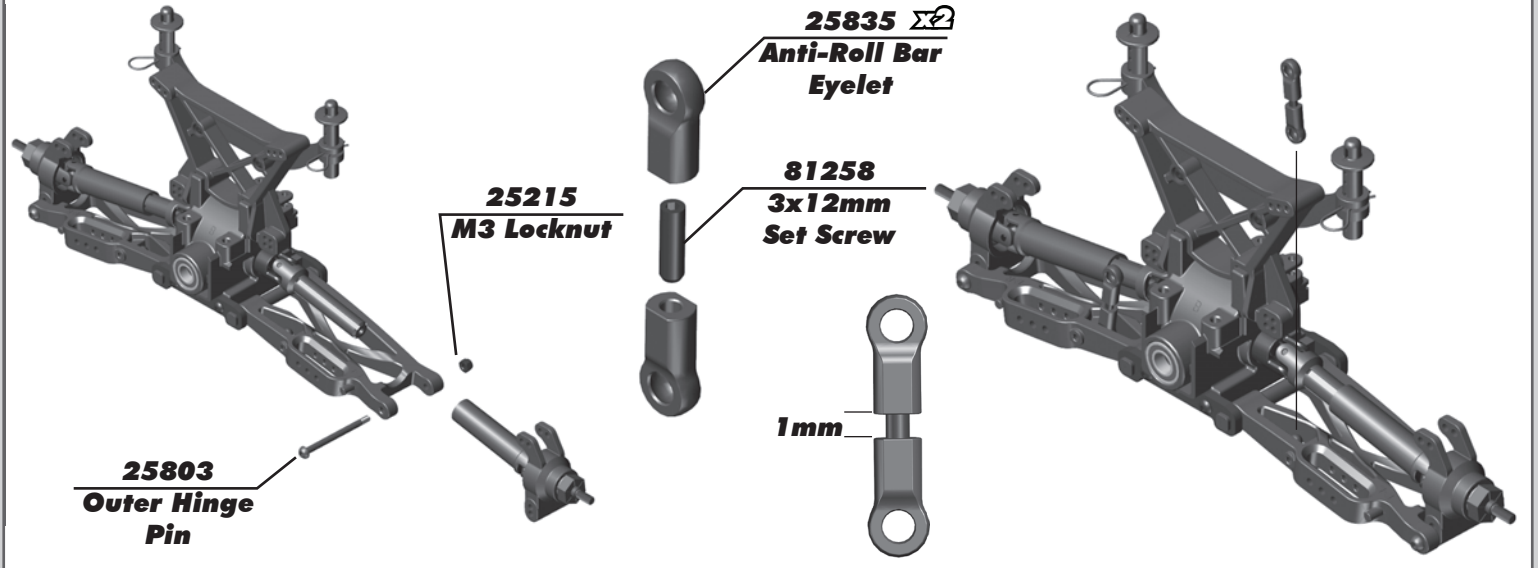

:: Step 26

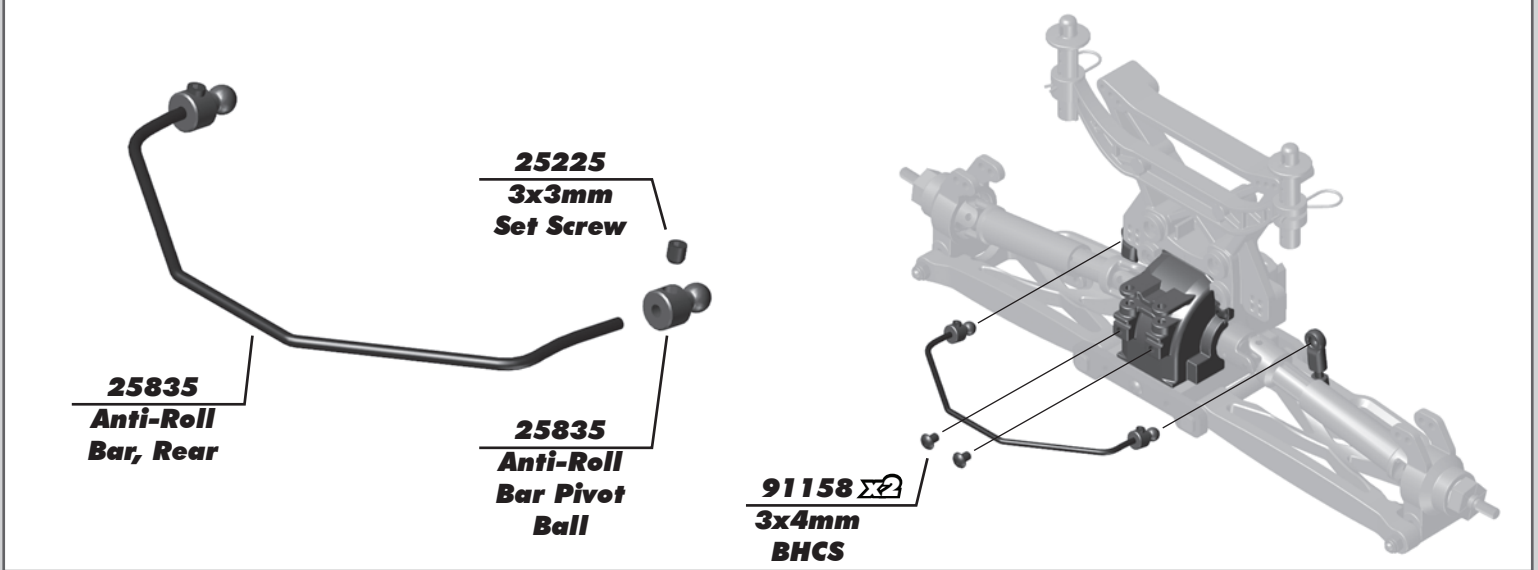

:: Step 27

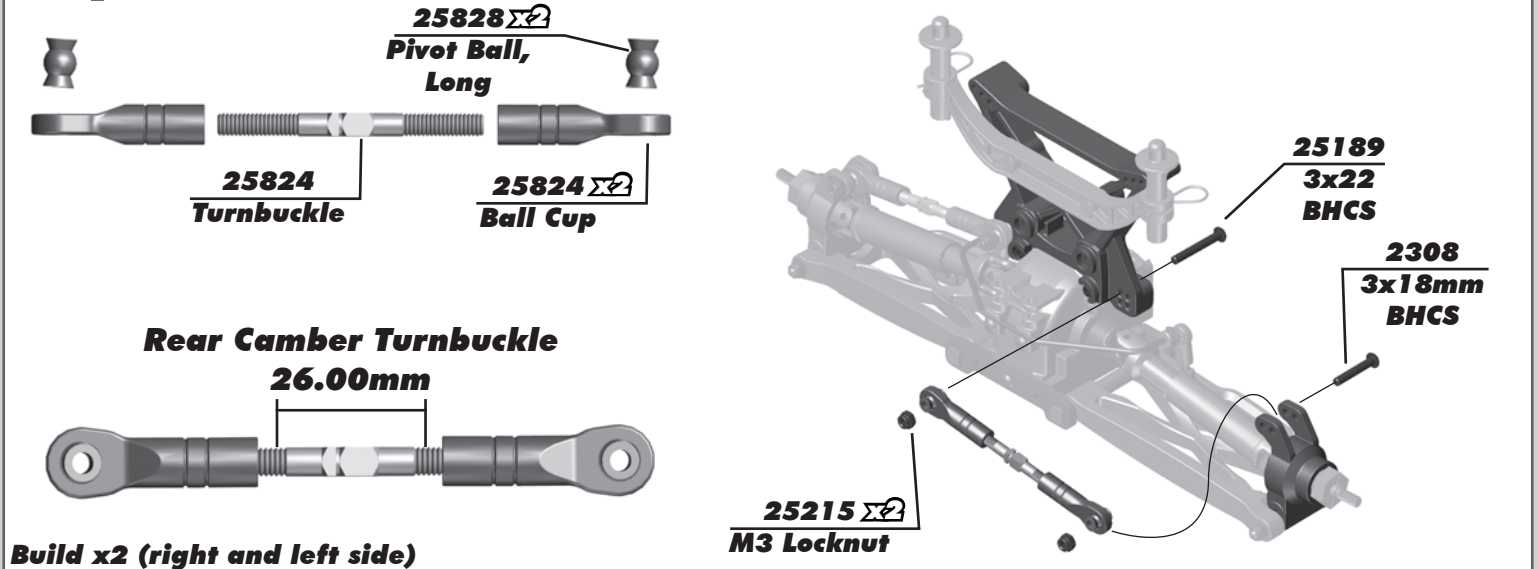

:: Step 28

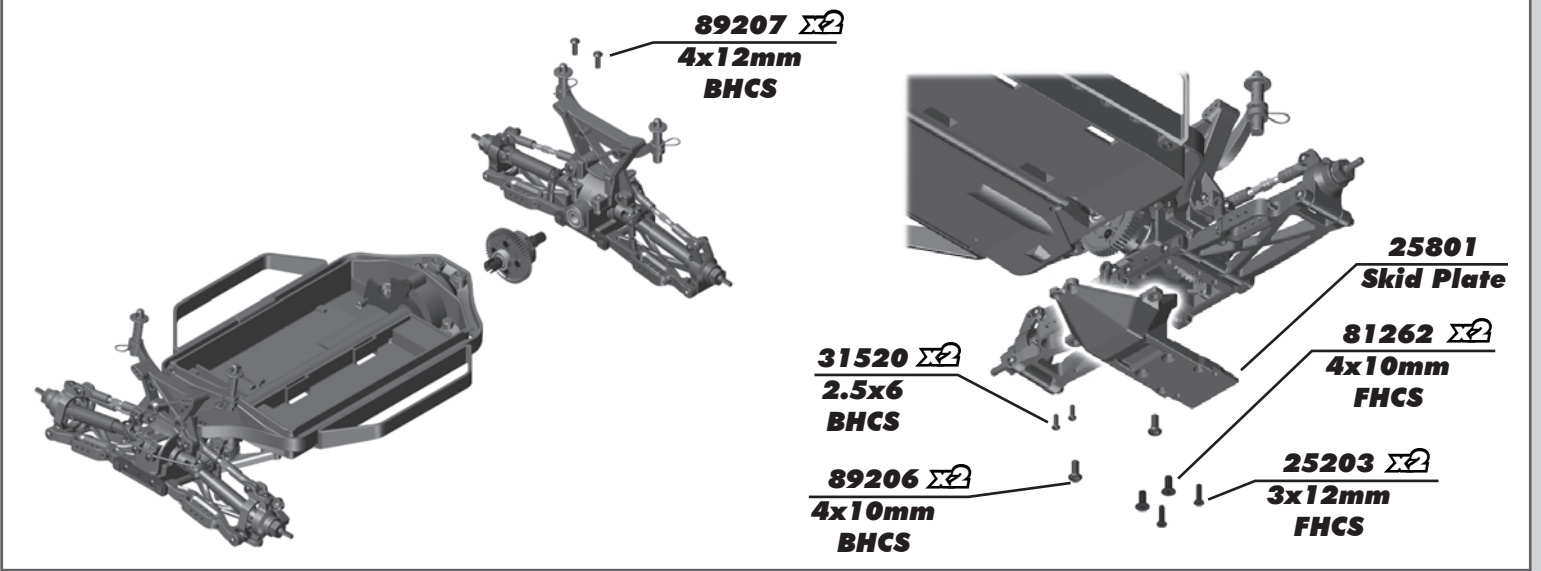

:: Step 29

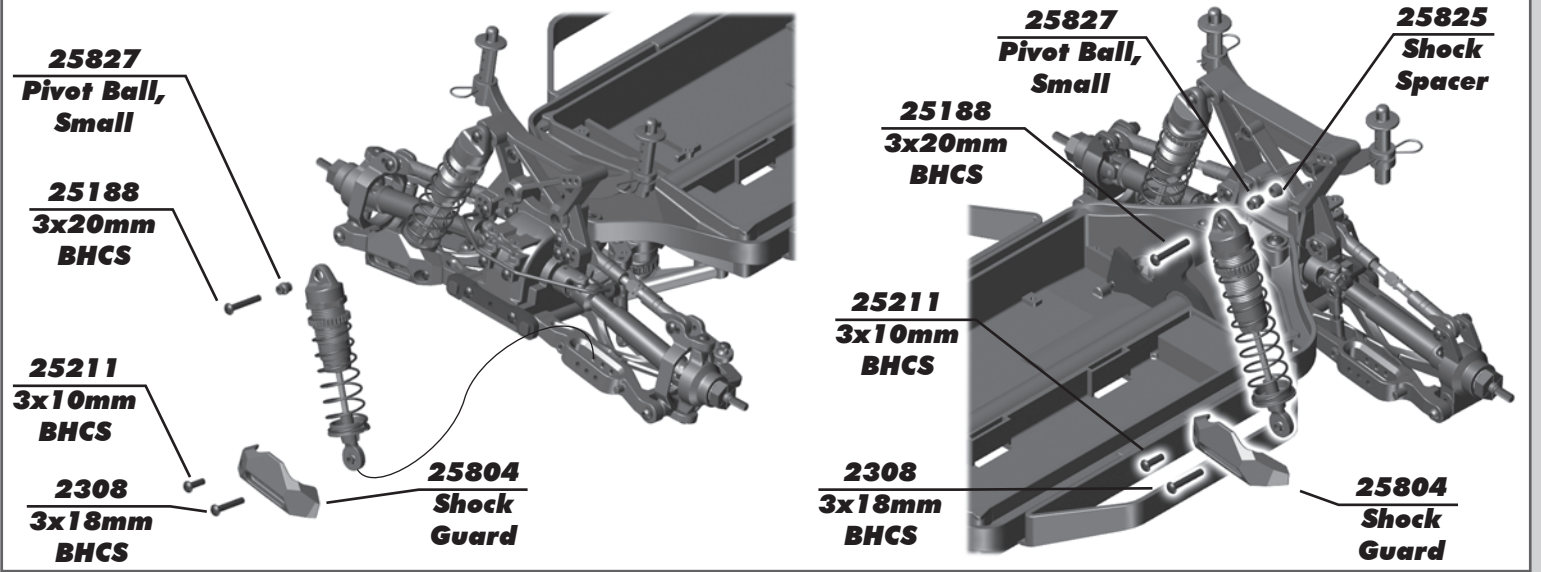

:: Step 30

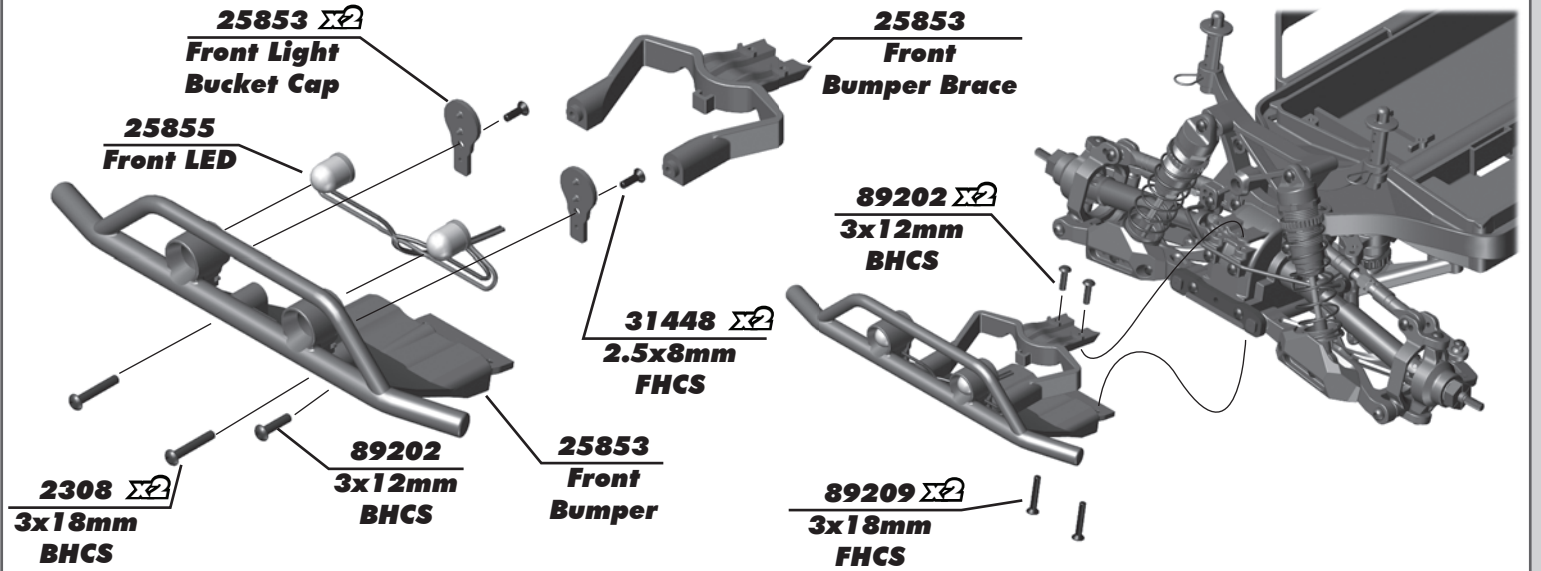

:: Step 31

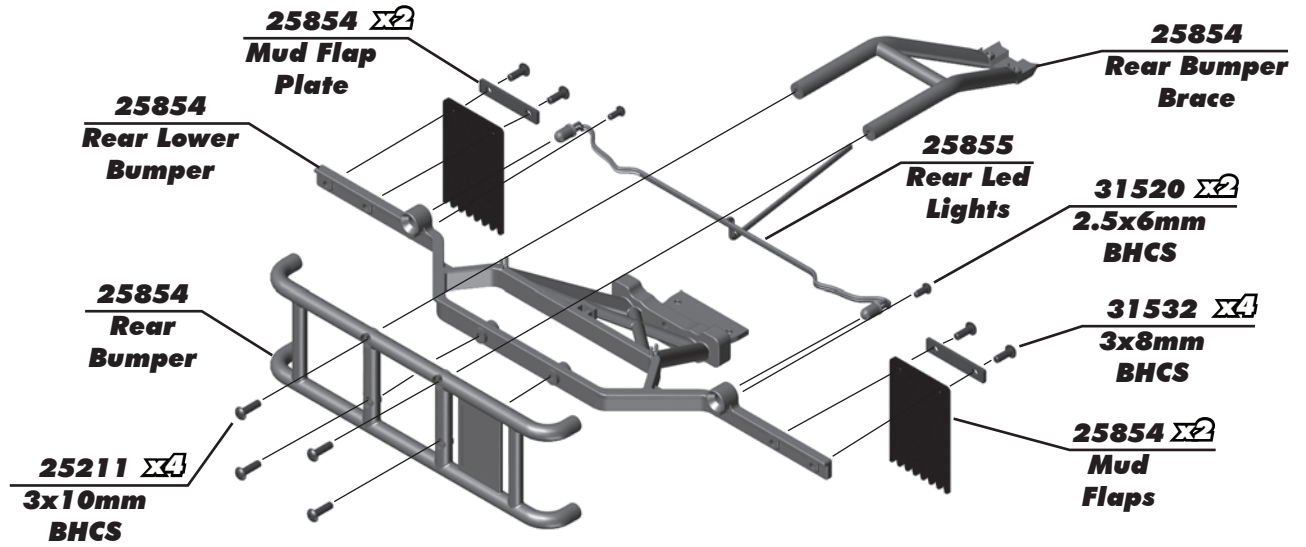

:: Step 32

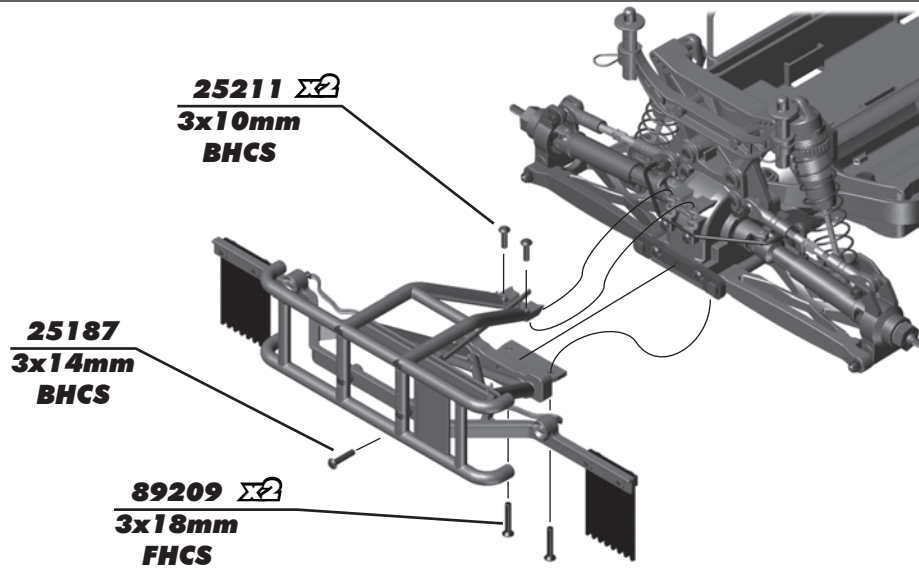

:: Step 33

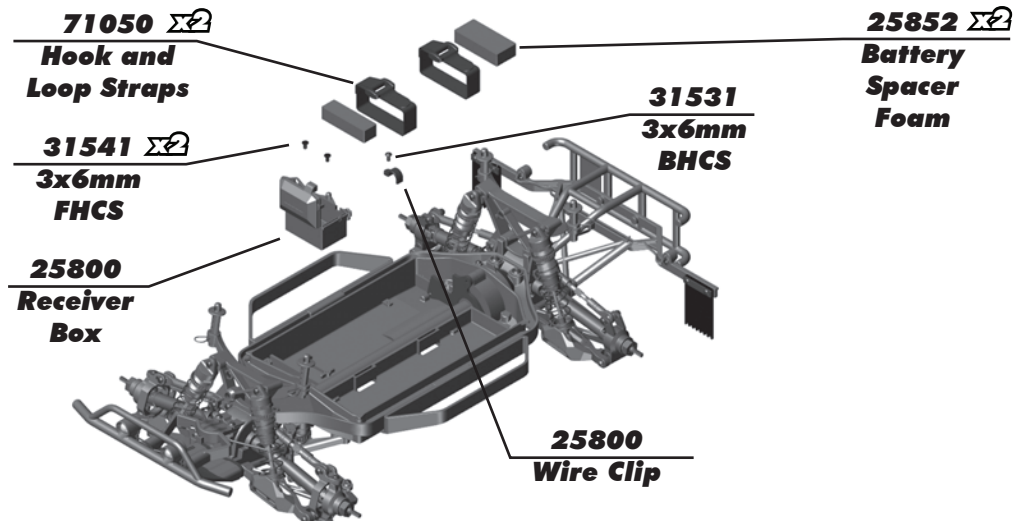

:: Step 34

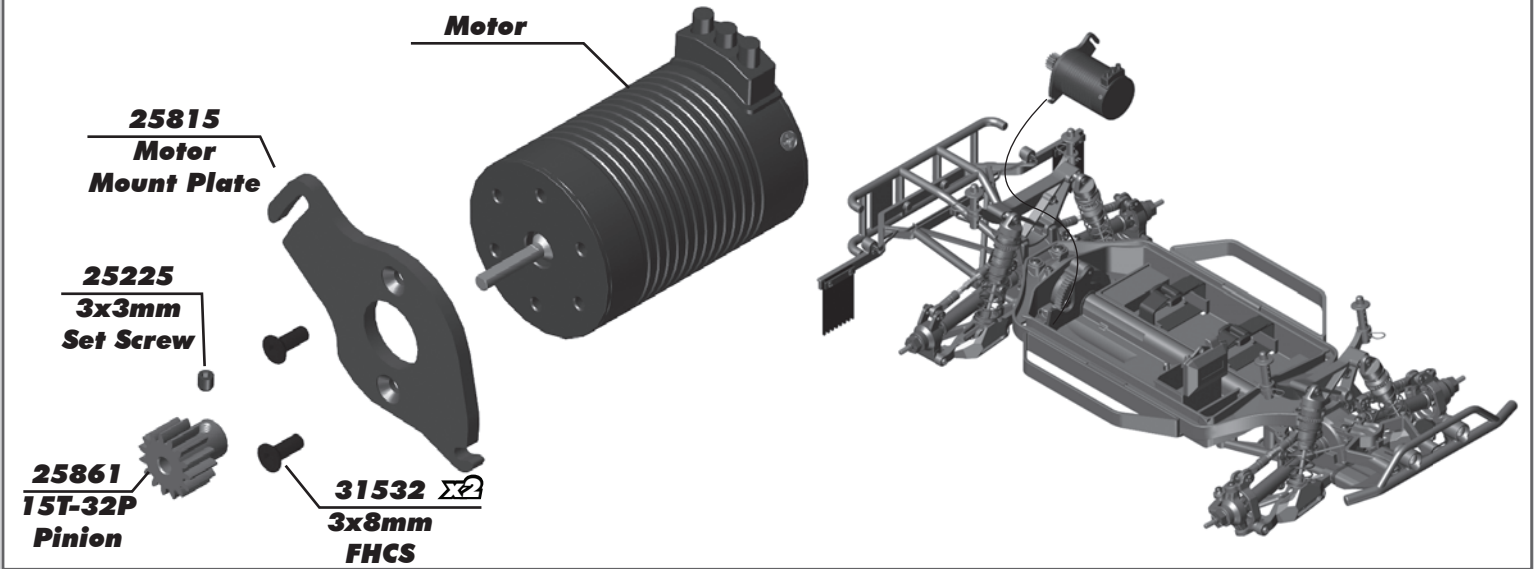

:: Step 35

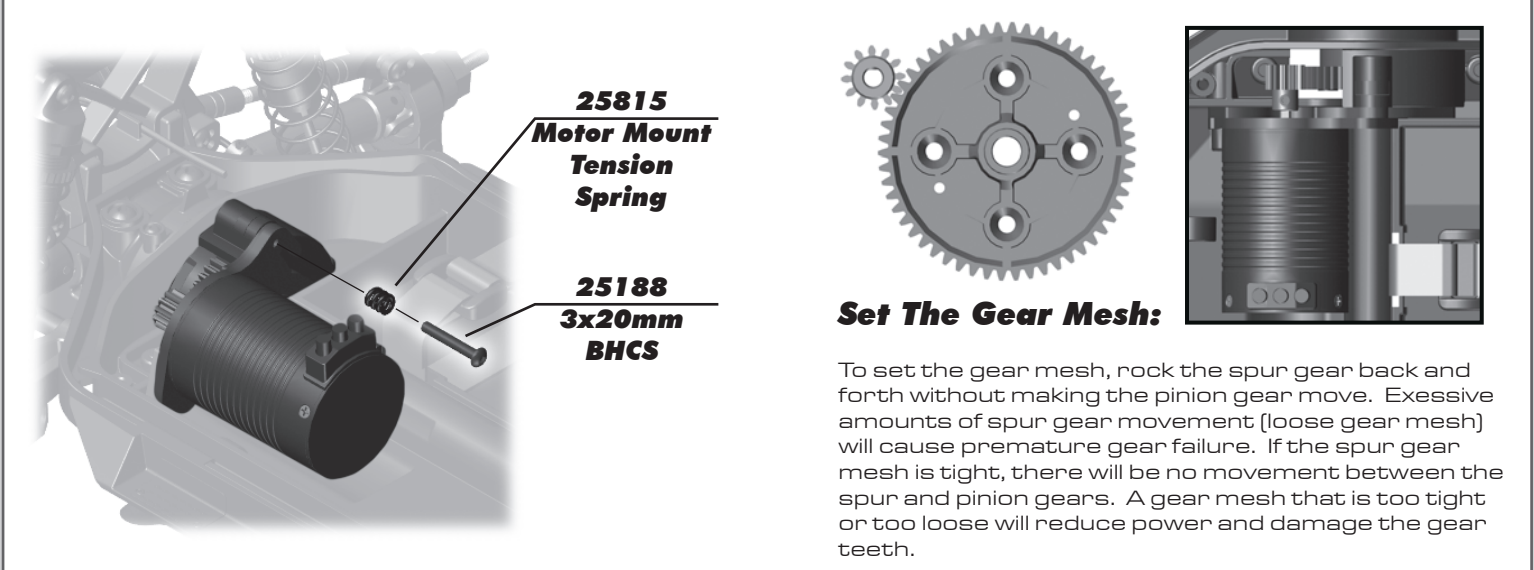

:: Step 36

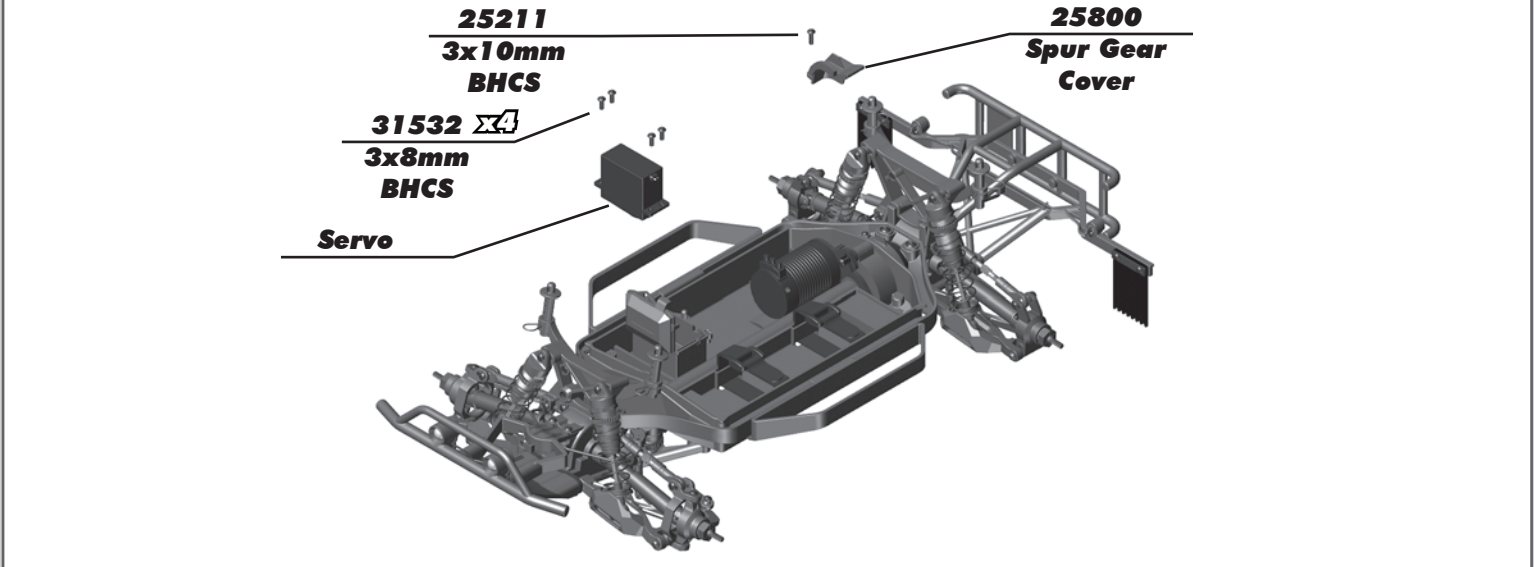

:: Step 37

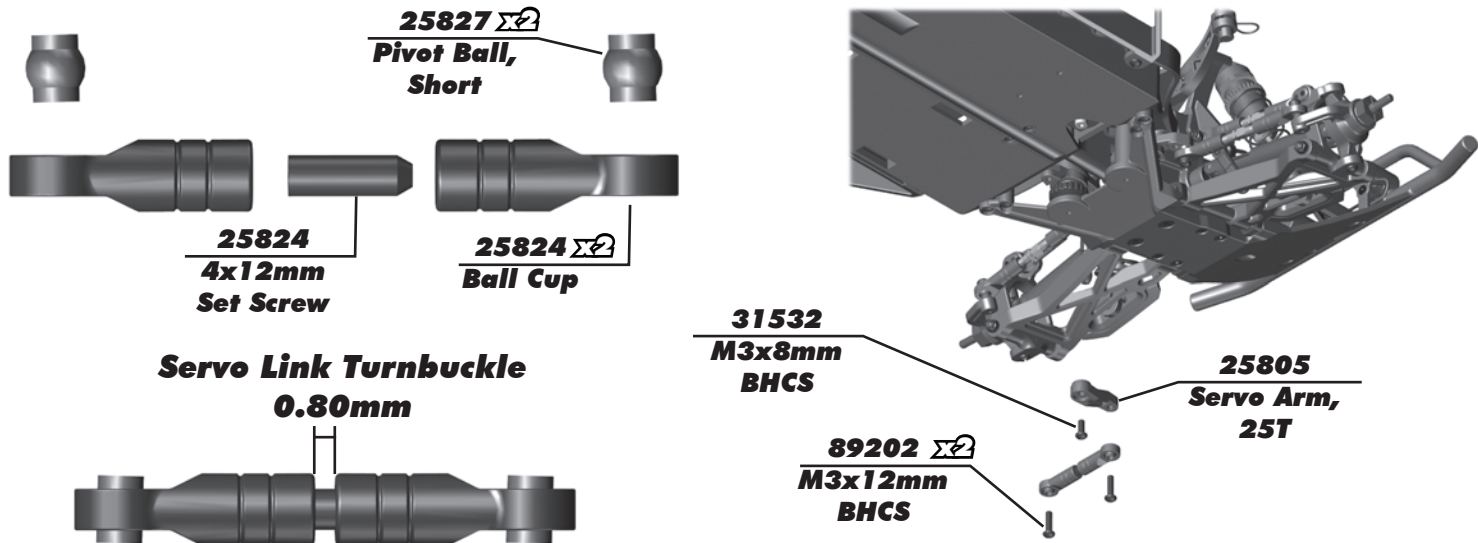

:: Step 38

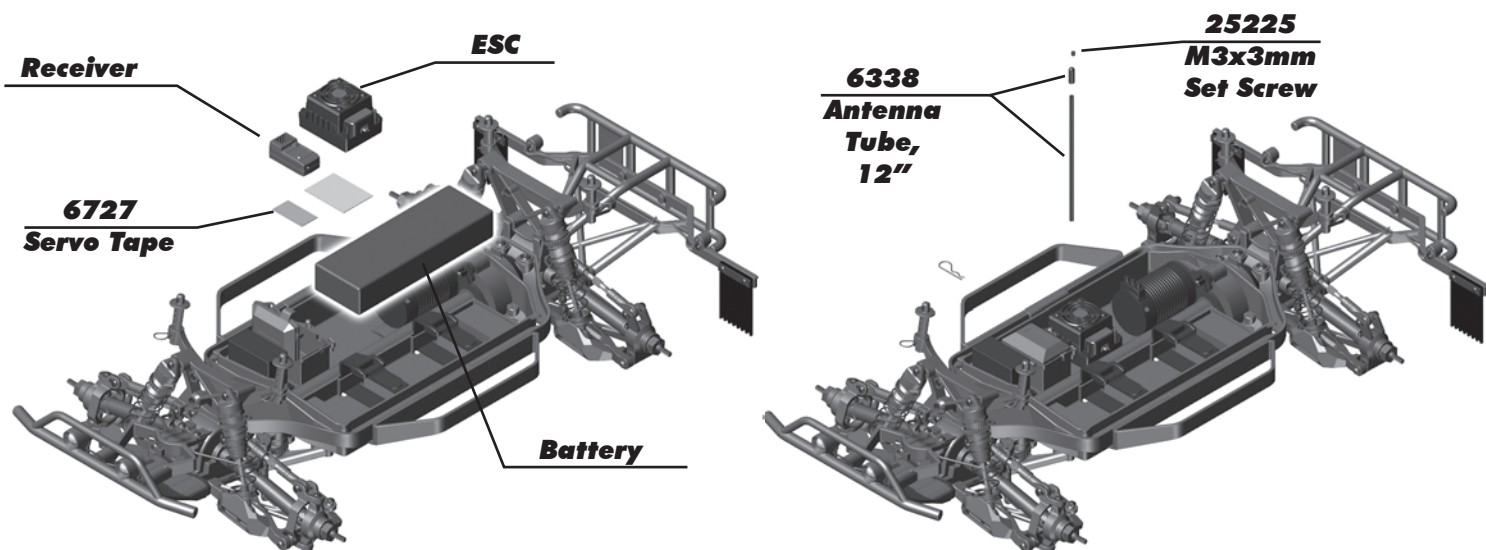

:: Step 39

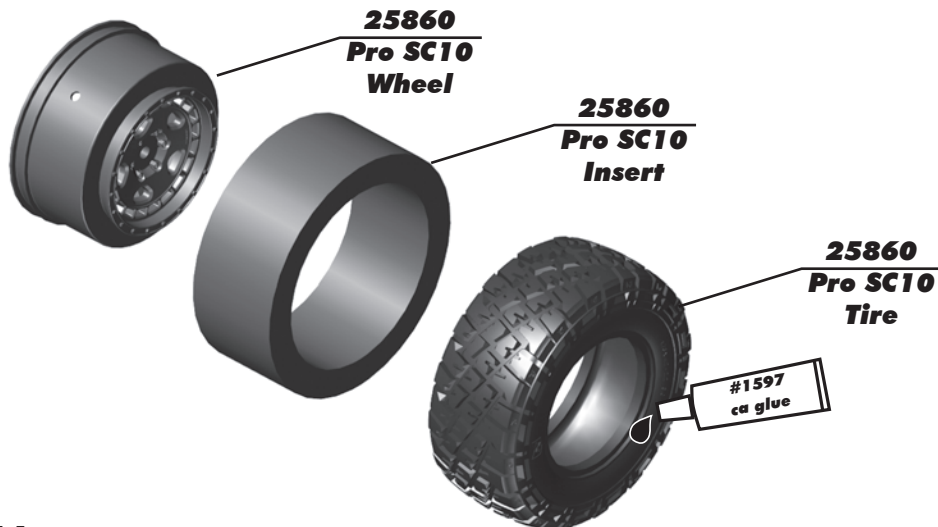

Carefully apply ca glue (tire adhesive) to the tire bead on the side. Do one side at a time, allowing it to dry before gluing the other side!

CA glue not included!

Build 4

:: Step 40

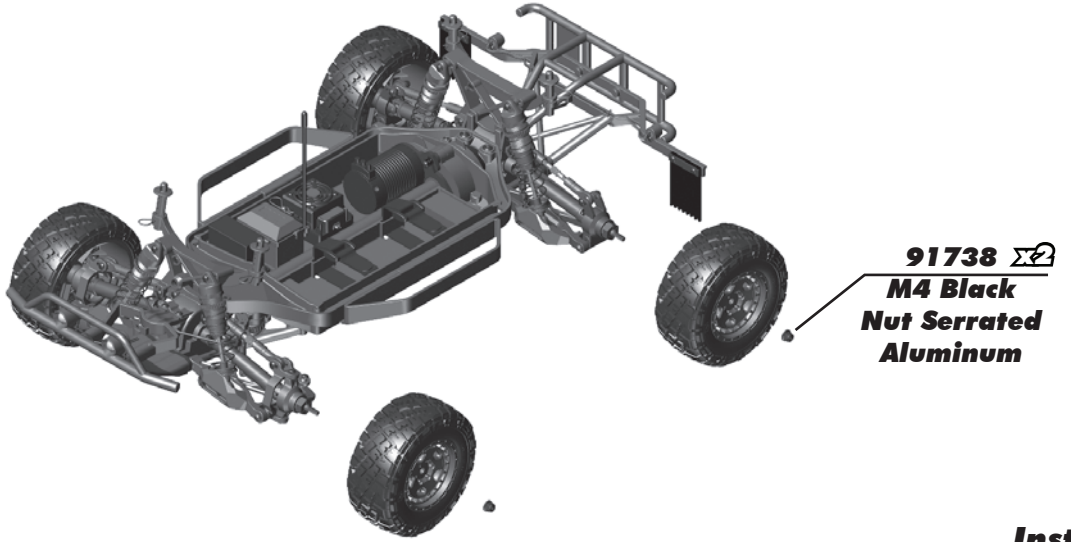

Install 4

:: Step 41

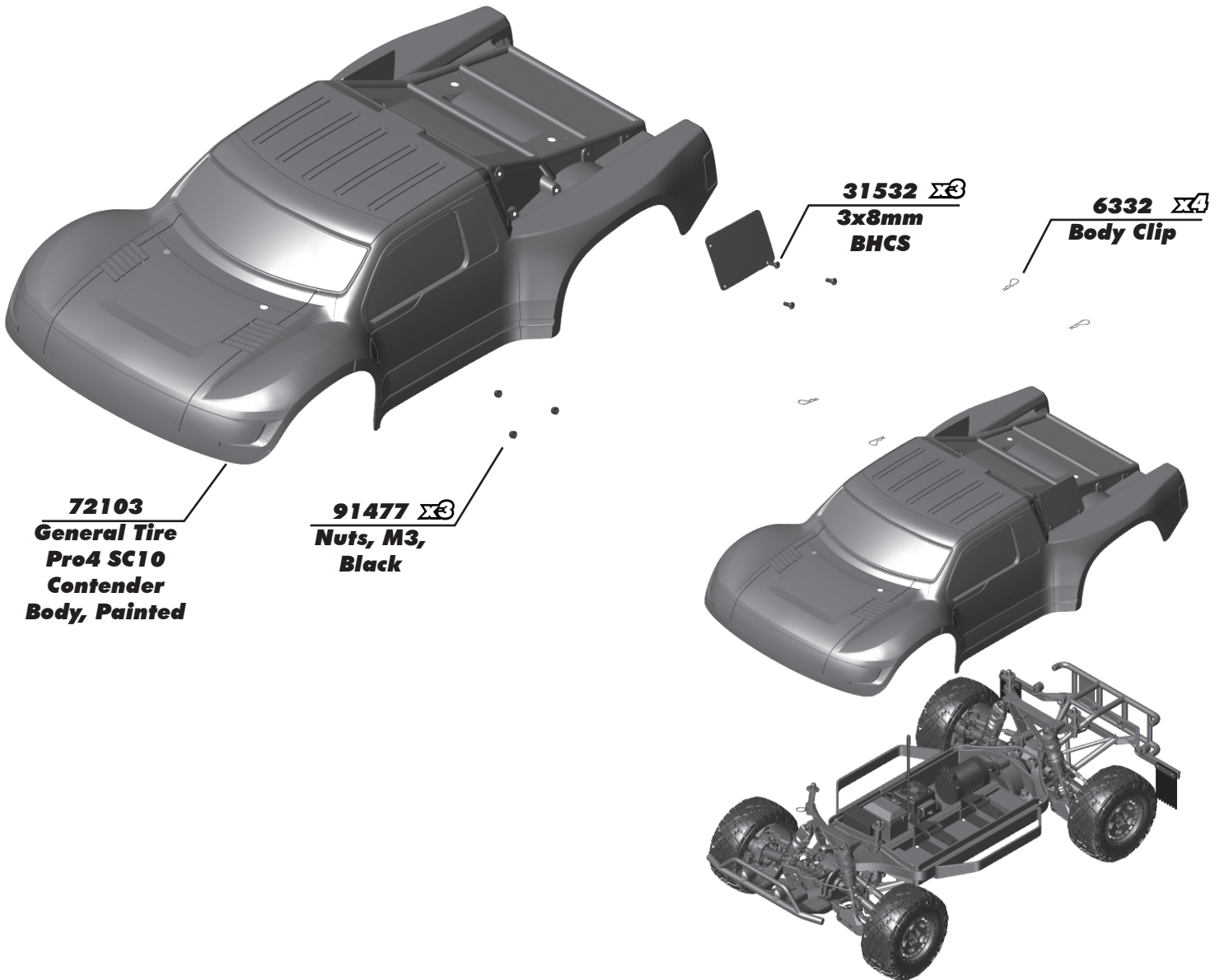

:: Tuning Tips**Tips for Beginners:**

Before making any changes to the standard setup, make sure you can get around the track without crashing. Changes to your vehicle will not be beneficial if you can't stay on the track. Your goal is consistent laps. Once you can get around the track consistently, start tuning your vehicle. Make only ONE adjustment at a time, testing it before making another change. If the result of your adjustment is a faster lap, mark the change on the included setup sheet (make additional copies of the sheet before writing on it). If your adjustment results in a slower lap, revert back to the previous setup and try another change. When you are satisfied with your vehicle, fill in the setup sheet thoroughly and file it away. Use this as a guide for future track days or conditions. Periodically check all moving suspension parts. Suspension components must be kept clean and move freely without binding to prevent poor and/or inconsistent handling.

Set The Gear Mesh:

You should be able to rock the spur gear back and forth in the teeth of the pinion gear without making the pinion gear move. If the spur gear mesh is tight, then loosen the #25188 screw and move the motor away, then try again. A gear mesh that is too tight or too loose will reduce power and damage the gear teeth.

Front Camber:

Camber describes the angle at which the tire and wheel rides when looked at from the front. Negative camber means that the tire leans inward at the top. A good starting camber setting is -1° . Positive camber, where the top of the tire is leaning out, is not recommended. Optional #1719 camber gauge can be used to more accurately set camber.

Rear Camber:

Camber describes the angle at which the tire and wheel rides when looked at from the back. Negative camber means that the tire leans inward at the top. A good starting camber setting is -1° . Adding a small amount of positive camber, where the top of the tire is leaning out, will tend to improve straight-line acceleration on loose tracks. Optional #1719 camber gauge can be used to more accurately set camber.

Front Camber Links:

Changing the length of the camber link is considered a bigger step than adjusting the ball end height on the tower. Shortening the camber link (or lowering the ball end) will give the front end less roll and quicken steering response. Lengthening the camber link (or raising the ball end) will give the front more roll and slower steering response. Longer camber links are typically used on high grip tracks and shorter links tend to work better on medium-grip loose tracks.

Rear Camber Link:

Changing the length of the camber link is considered a bigger step than adjusting the ball end height on the rear chassis brace. Shortening the camber link (or lowering the ball end) will give the rear end less roll and the car will tend to accelerate or "square up" better. Lengthening the camber link (or raising the ball end) will give the rear more roll and more cornering grip. Longer camber links are typically used on high grip tracks, while shorter links tend to work better on medium grip loose tracks. The kit setting is the best compromise of cornering grip and acceleration.

Ackermann:

Ackermann is the angle difference between the front wheels when they are turned to steer the car. For minimal tire slip, it is standard for the inside wheel to steer to a greater angle than the outside wheel. If corner entry steering is too aggressive, try increasing the Ackermann by moving the ball studs to the rearward holes. Increasing the Ackermann will increase the angle difference of the front wheels when steered, resulting in a more stable car on corner entry.

:: Shocks

25825	Rival MT10 Shock Set	1
25826	Rival MT10 Shock Shaft Set	2ea.
25827	Pivot Balls, Short	10
25831	Rival MT10 Shock Rebuild Kit	1
25832	Rival MT10 Shock Spring Set	2ea.

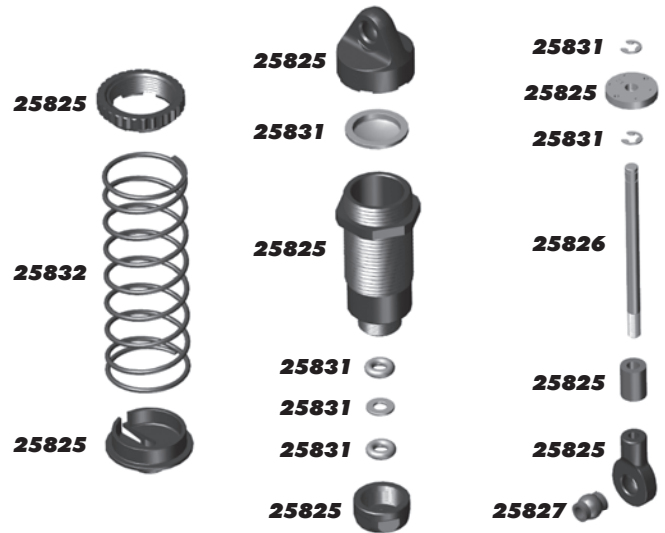

:: Gear Differentials

25807	Rival MT10 Differential Cases	1
25808	Rival MT10 Ring Gear, 37T	1
25810	Rival MT10 Front & Rear Diff Rebuild Kit	1
25811	Rival MT10 Spur Gear, 54T - 32P	1
25812	Rival MT10 Center Diff Rebuild Kit	1
31350	M2.5x10mm FHCS	10
31448	M2.5x8mm FHCS	10
89208	M3x14mm FHCS	10
91563	FT Bearings, 10x15x4mm	4
91564	FT Bearings, 8x16x5mm	4

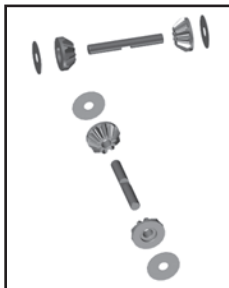

Center Diff
25812
Front/Rear Diff
25810

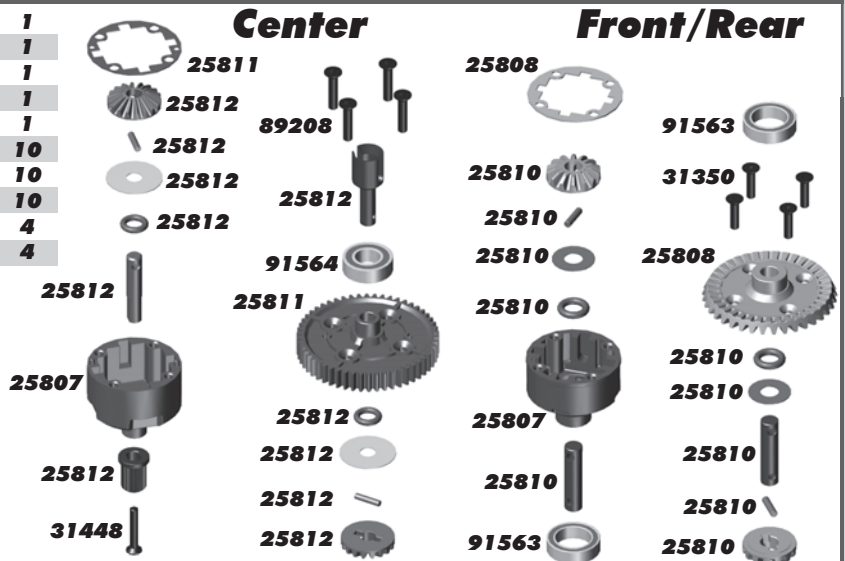

:: Shock Fluid

5420	10 Weight Silicone Shock Fluid	2oz.
5427	15 Weight Silicone Shock Fluid	2oz.
5421	20 Weight Silicone Shock Fluid	2oz.
5424	22.5 Weight Silicone Shock Fluid	2oz.
5428	25 Weight Silicone Shock Fluid	2oz.
5426	27.5 Weight Silicone Shock Fluid	2oz.
5422	30 Weight Silicone Shock Fluid	2oz.
5432	32.5 Weight Silicone Shock Fluid	2oz.
5429	35 Weight Silicone Shock Fluid	2oz.
5433	37.5 Weight Silicone Shock Fluid	2oz.
5423	40 Weight Silicone Shock Fluid	2oz.
5434	42.5 Weight Silicone Shock Fluid	2oz.
5430	45 Weight Silicone Shock Fluid	2oz.
5438	47.5 Weight Silicone Shock Fluid	2oz.
5435	50 Weight Silicone Shock Fluid	2oz.
5431	55 Weight Silicone Shock Fluid	2oz.
5436	60 Weight Silicone Shock Fluid	2oz.
5437	70 Weight Silicone Shock Fluid	2oz.
5425	80 Weight Silicone Shock Fluid	2oz.



:: Diff Fluid

5451	Silicone Diff Fluid 2,000CST	1
5452	Silicone Diff Fluid 3,000CST	1
5444	Silicone Diff Fluid 4,000CST	1
5453	Silicone Diff Fluid 5,000CST	1
5446	Silicone Diff Fluid 6,000CST	1
5454	Silicone Diff Fluid 7,000CST	1
5455	Silicone Diff Fluid 10,000CST	1
5456	Silicone Diff Fluid 20,000CST	1
5457	Silicone Diff Fluid 30,000CST	1
5458	Silicone Diff Fluid 60,000CST	1
5448	Silicone Diff Fluid 80,000CST	1
5459	Silicone Diff Fluid 100,000CST	1
5461	Silicone Diff Fluid 200,000CST	1
5463	Silicone Diff Fluid 500,000CST	1
5465	Silicone Diff Fluid 1,000,000CST	1



:: Front Bumpers

2308	M3x18mm BHCS	10
25853	Pro4 SC10 Front Bumper	1
25855	Pro4 SC10 LED Light Kit	1
31448	M2.5x8mm FHCS	10
89202	M3x12mm BHCS	10

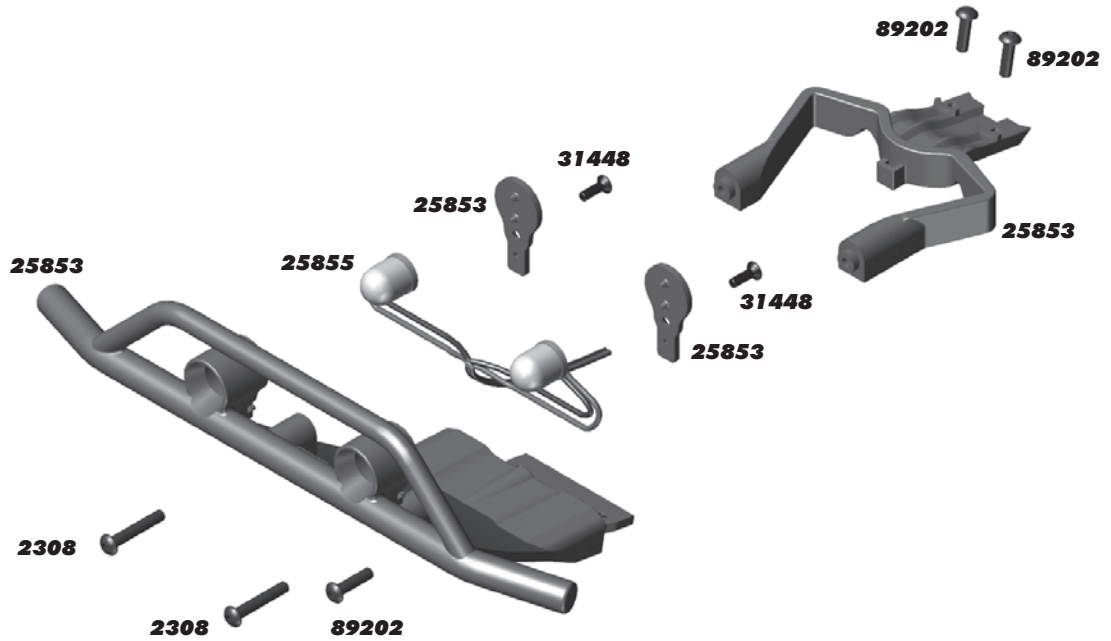

:: Rear Bumpers

25211	M3x10mm BHCS	10
25187	M3x14mm BHCS	10
25854	Pro4 SC10 Rear Bumper	1
25855	Pro4 SC10 LED Light Kit	1
31520	M2.5x6mm BHCS	10
31532	M3x8mm BHCS	10

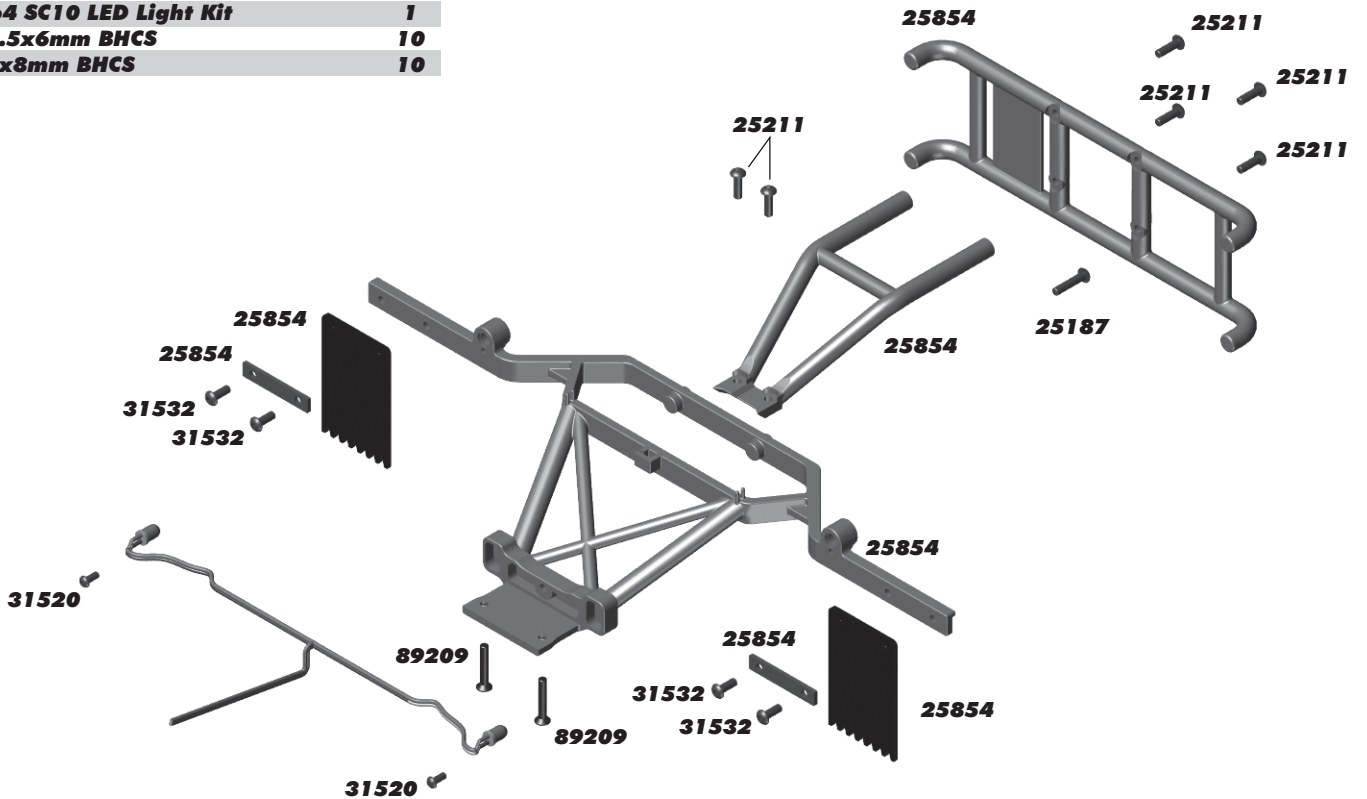

:: Steering Bellcrank

8680	5x8x2.5mm Bearing	4
25215	M3 Locknut	10
25805	Rival MT10 Steering Bellcrank Set	1
25819	Rival MT10 Hat Bushing Set	1
41079	M2.5x6mm SHCS	10
89202	M3x12mm BHCS	10

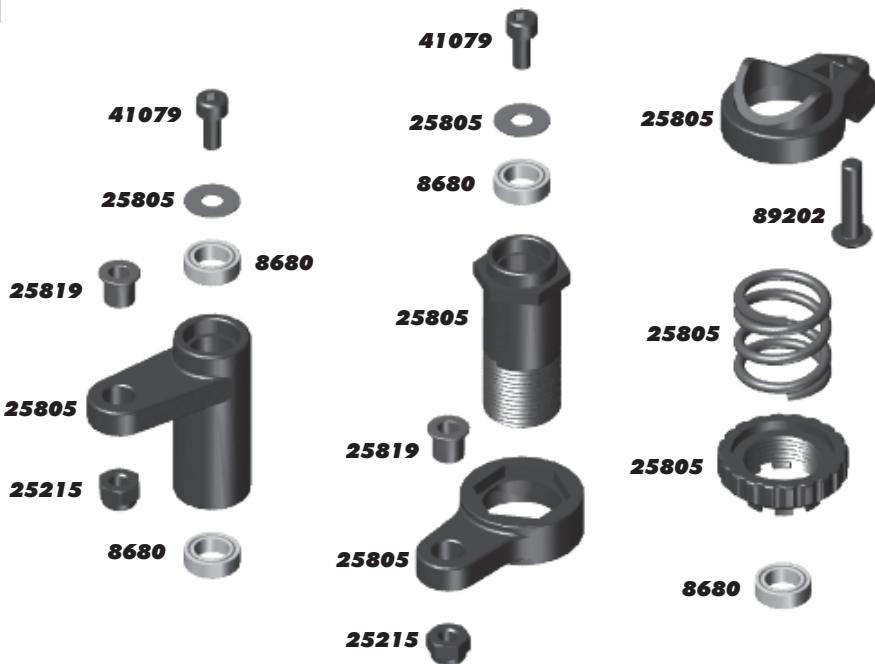

:: Front Bulkhead

25187	M3x14mm BHCS	10
25203	M3x12mm FHCS	10
25211	M3x10mm BHCS	10
25801	Rival MT10 Skid Plates	1
25805	Rival MT10 Steering Bellcrank Set	1
31532	M3x8mm BHCS	10
81262	M4x10mm FHCS	10
89202	M3x12mm BHCS	10
89209	M3x18mm FHCS	10

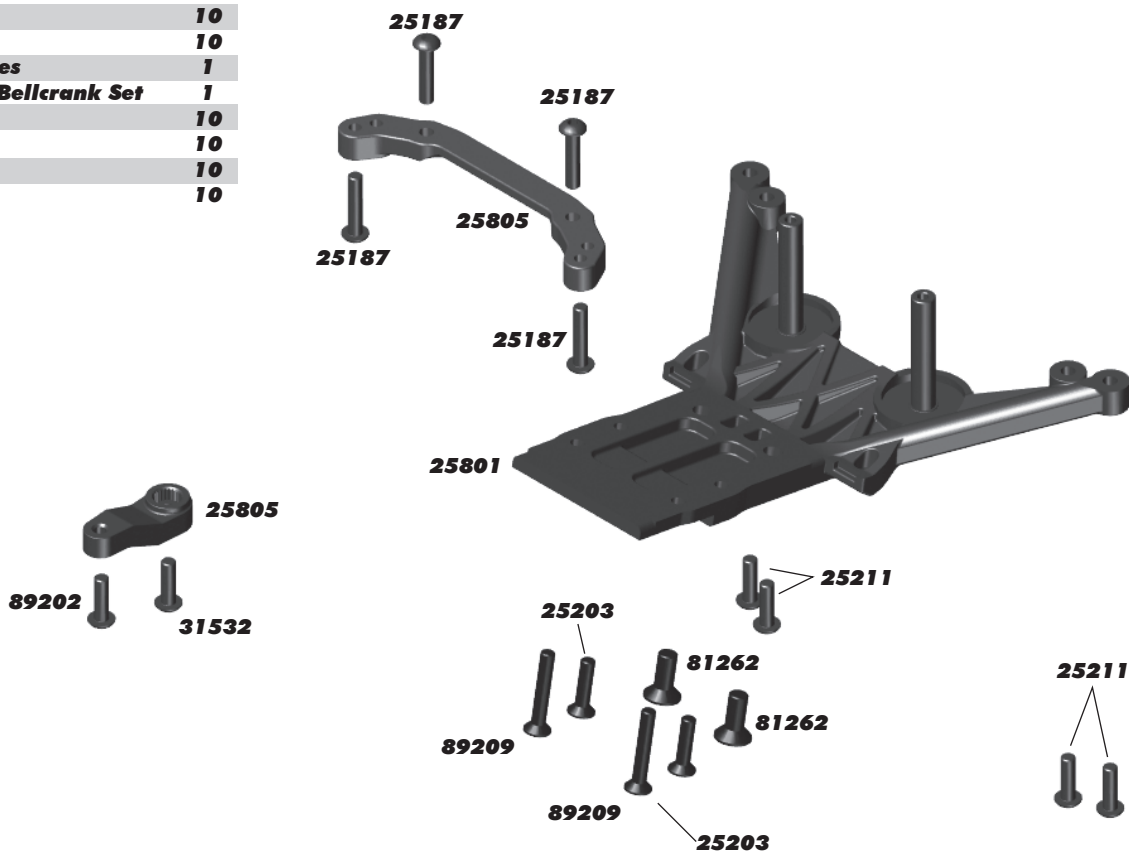

:: Front Gearbox

25211	M3x10mm BHCS	10
25618	5x11x4mm Bearing	4
25802	Rival MT10 Arm Mounts	1
25803	Royal MT10 Hinge Pin Set	1
25806	Rival MT10 Front & Rear Gearboxes	1
25809	Rival MT10 Oudrive Shaft & Pinion Set	1
31350	M2.5x10mm FHCS	10
89202	M3x12mm BHCS	10
91563	FT 10x15x4mm Bearing	4

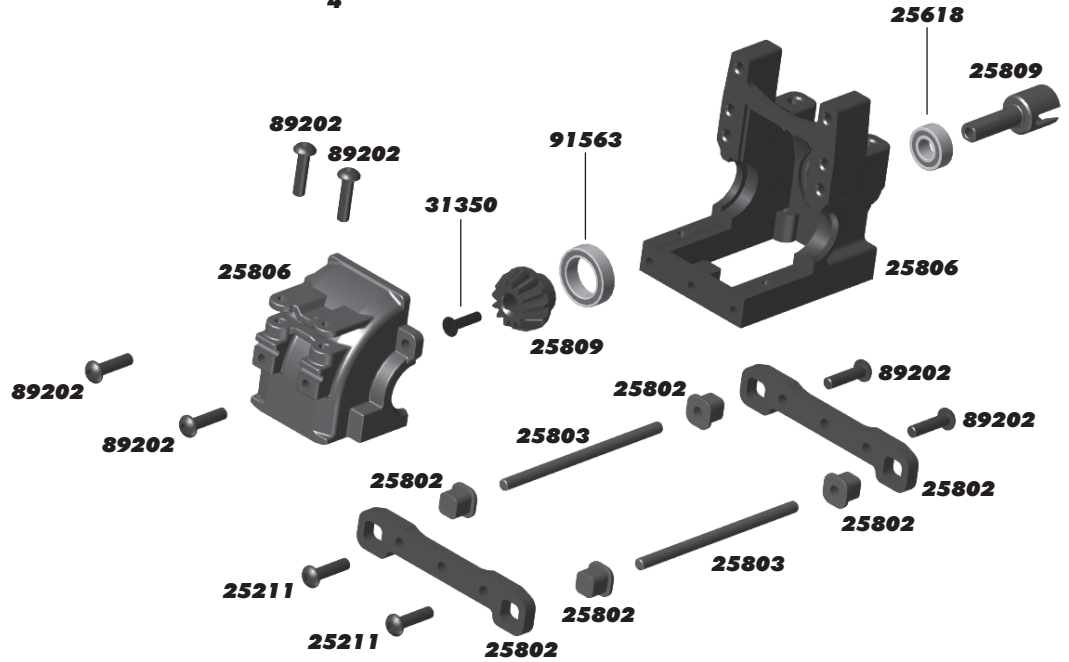

:: Rear Gearbox

25203	M3x12mm FHCS	10
25211	M3x10mm BHCS	10
25801	Rival MT10 Skid Plates	1
25802	Rival MT10 Arm Mounts	1
25803	Royal MT10 Hinge Pin Set	1
25806	Rival MT10 Front & Rear Gearboxes	1
25809	Rival MT10 Oudrive Shaft & Pinion Set	1
25843	12x18x4mm	4
31520	M2.5x6mm BHCS	10
81262	M4x10mm FHCS	10
89202	M3x12mm BHCS	10
89203	M3x16mm BHCS	10
89206	M4x10mm BHCS	10
91158	M3x4mm BHCS	10
91564	FT 8x16x5mm Bearings	4

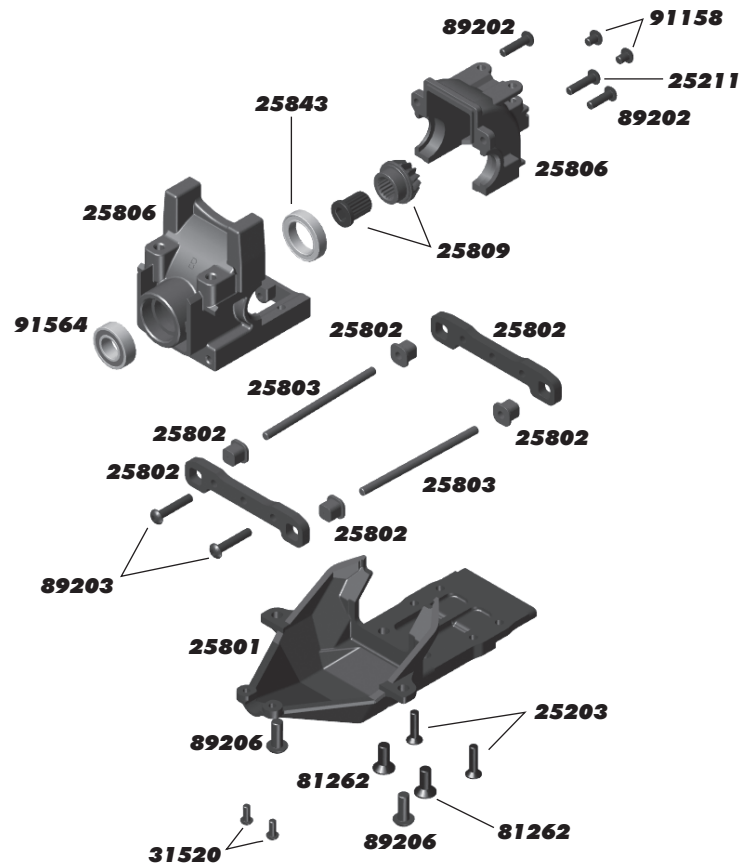

:: Front Arm

2308	M3x18mm BHCS	10
25187	M3x14mm BHCS	10
25211	M3x10mm BHCS	10
25215	M3 Locknut	10
25618	5x11x4mm Bearings	4
25803	Rival MT10 Hinge Pin Set	1
25804	Rival MT10 Suspension Arm Set	1
25818	Rival MT10 Caster & Steering Block Set	1
25819	Rival MT10 Hat Bushing Set	1
25820	Rival MT10 12mm Wheel Hexes	4
25821	Rival MT10 Drive Shaft Set	1
89203	M3x16mm BHCS	10
91563	FT 10x15x4mm Bearings	4
91738	M4 Black Nut, Serrated Aluminum	10

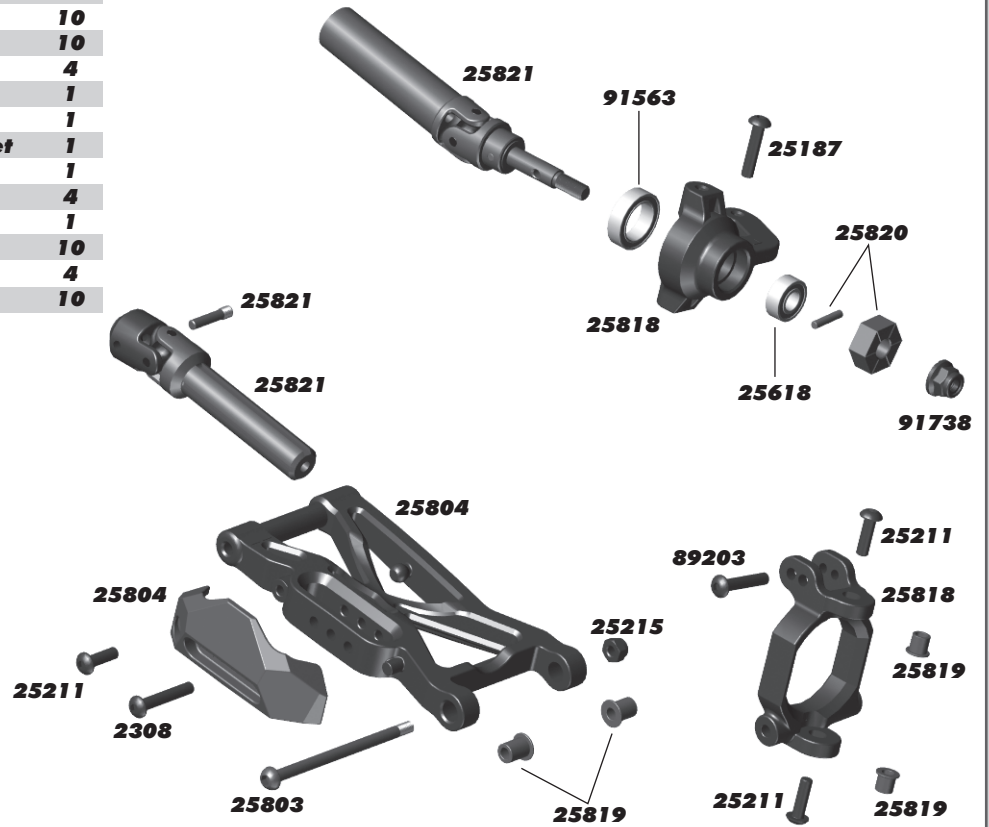

:: Rear Arm

2308	M3x18mm BHCS	10
25211	M3x10mm BHCS	10
25215	M3 Locknut	10
25618	5x11x4mm Bearings	4
25803	Rival MT10 Hinge Pin Set	1
25804	Rival MT10 Suspension Arm Set	1
25818	Rival MT10 Caster & Steering Block Set	1
25820	Rival MT10 12mm Wheel Hexes	4
25821	Rival MT10 Drive Shaft Set	1
91563	FT 10x15x4mm Bearings	4
91738	M4 Black Nut, Serrated Aluminum	10

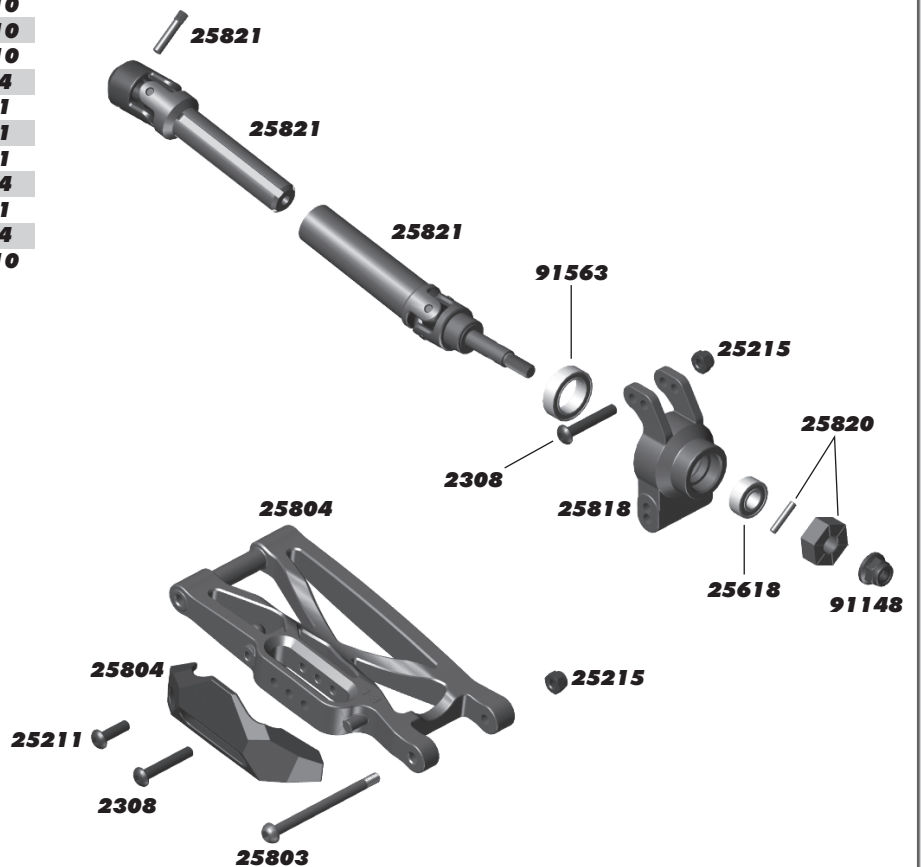

:: Front Shock Tower

6332	Body Clips	10
25188	M3x20mm BHCS	10
25189	M3x22mm BHCS	10
25211	M3x10mm BHCS	10
25215	M3 Locknut	10
25816	Rival MT10 Shock Tower Set	1
25817	Rival MT10 Body Mount Set	1
25827	Rival MT10 Pivot Balls, Short	10
89202	M3x12mm BHCS	10

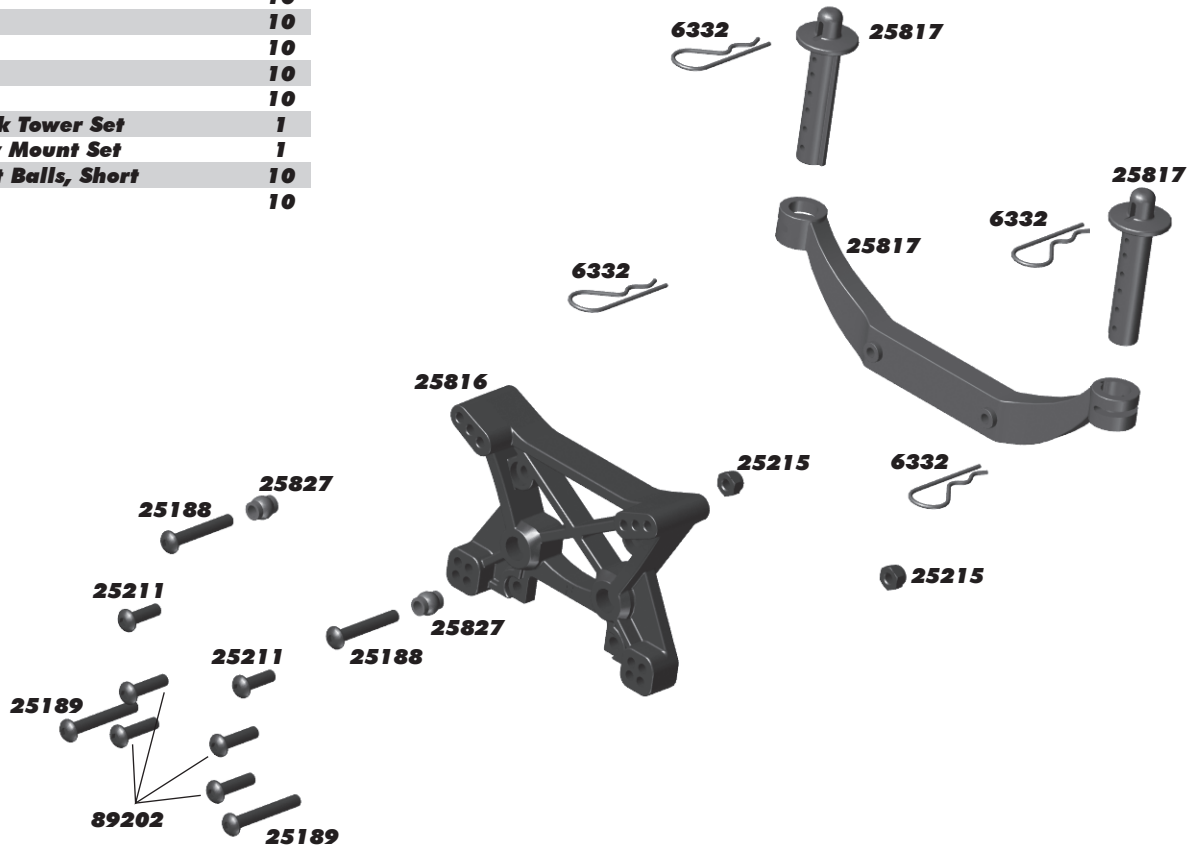

:: Rear Shock Tower

6332	Body Clips	10
25187	M3x14mm BHCS	10
25188	M3x20mm BHCS	10
25189	M3x22mm BHCS	10
25211	M3x10mm BHCS	10
25215	M3 Locknut	10
25816	Rival MT10 Shock Tower Set	1
25817	Rival MT10 Body Mount Set	1
25827	Rival MT10 Pivot Balls, Short	10
25825	Rival MT10 Shock Set	1

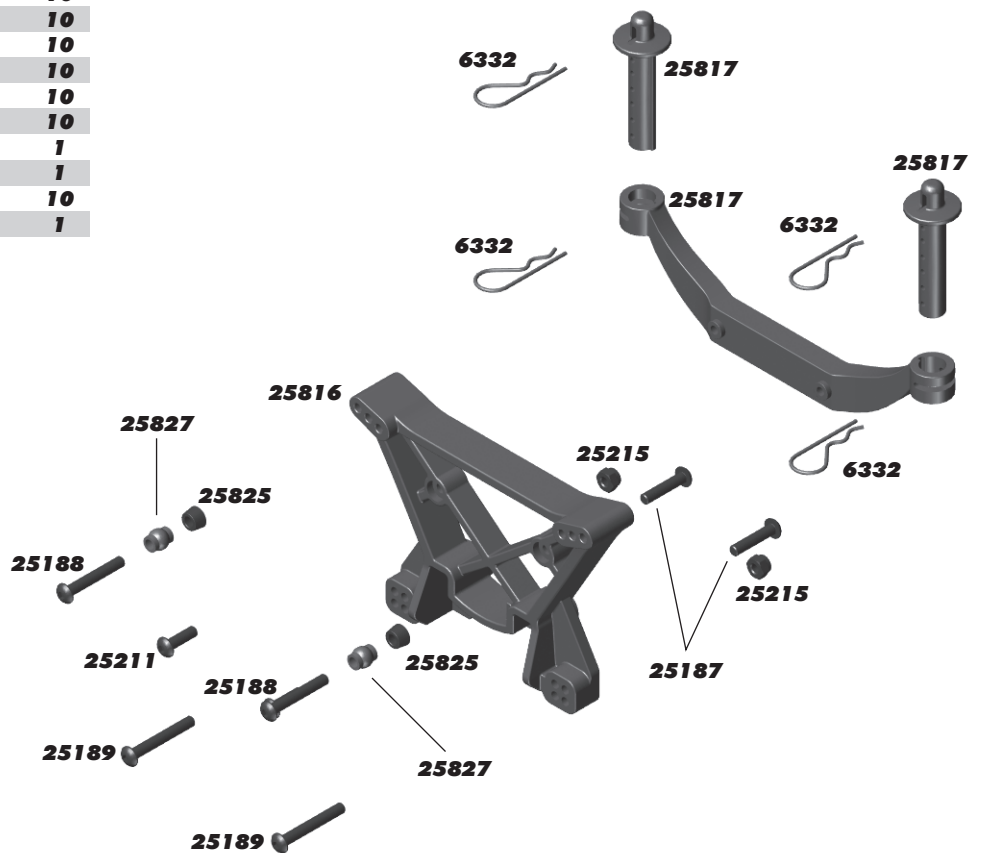

:: Chassis

6332	Body Clips	10
6338	Antenna Tube, 12"	1
25188	M3x20mm BHCS	10
25211	M3x10mm BHCS	10
25225	M3x3mm Set Screw	10
25815	Rival MT10 Motor Mount Set	1
25852	Pro4 SC10 Chassis, Guards, Cover, Foam	1
25856	Pro4 SC10 Center Drive Shaft	1
25861	15T-32P Pinion Gear	1
31500	M3x2.5mm Set Screw	10
31519	M2.5x5mm BHCS	10
31520	M2.5x6mm BHCS	10
31531	M3x6mm BHCS	10
31532	M3x8mm BHCS	10
31541	M3x6mm FHCS	10
71050	Hook and Loop Straps	2
89207	M4x12mm BHCS	10
91158	M3x4mm BHCS	10

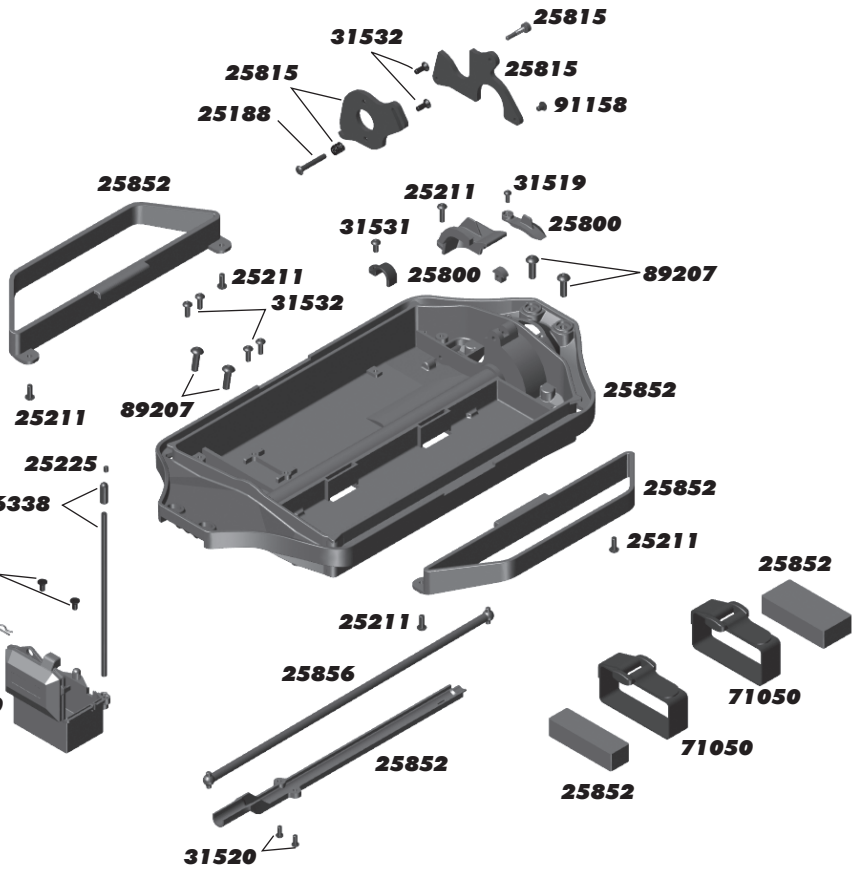

:: Turnbuckles / Swaybars / Wheels / Tires

25225	M3x3mm Set Screw	10
25824	Rival MT10 Turnbuckle Set	1
25827	Rival MT10 Pivot Balls, Short	10
25828	Rival MT10 Pivot Balls, Long	10
25835	Rival MT10 Front Anti-Roll Bar Set	1
25858	Pro4 SC10 Body, Painted	1
25860	Pro4 SC10 Off Road Tires & Method Wheels, Mounted	2
81258	M3x12mm Set Screw	10

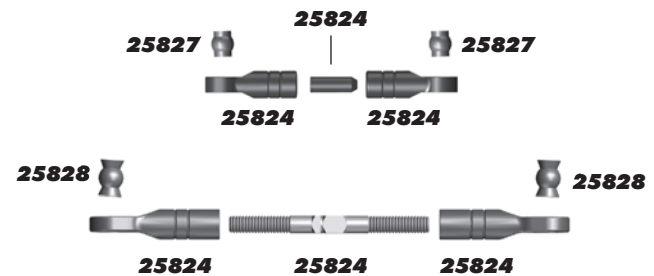

:: Lubes & Adhesives / Decals / Misc.

1105	FT Green Slime Shock Lube	1
1596	FT Locking Adhesive	1
1597	FT Tire Adhesive	1
6588	Black Grease - 4cc	1
6591	S.Diff Lube - 4cc	1
6636	Silicone Grease - 4cc	1
6727	Servo Tape	2
726	Reedy 2016 Sticker Set	1
3840	2016 Team Associated Decal Sheet	1

**:: MyLaps Transponders**

MLP10R120	MyLaps RC4 (3-wire) Transponder	1
MLP10R147	MyLaps RC4 (3 wire) Transponder, black	1
MLP40R222	MyLaps Transponder Holder	1

:: XP/AE Electronics

29203	AE XP120 2.4GHz 2CH Radio System	1
29204	AE XP-R4 2.4GHz 4CH Receiver	1
29257	AE XP130 2.4GHz 3CH Radio System	1

:: Reedy Batteries

302	AA Alkaline 1.5V (4)	1
751	Wolfpack LiPo 3300mAh 30C 7.4V w/T-Plug	1
752	Wolfpack LiPo 4000mAh 35C 7.4V w/T-Plug	1
753	Wolfpack LiPo 5400mAh 35C 7.4V w/T-Plug	1
755	Wolfpack LiPo 4500mAh 35C 11.1V w/T-Plug	1
758	Wolfpack LiPo 3000mAh 30C 7.4V w/T-Plug	1
759	Wolfpack LiPo 3000mAh 30C 11.1V w/T-Plug	1
27313	LiPo Pro TX/RX 2400mAh 7.4V Flat	1
27315	LiFe Pro TX/RX 1600mAh 6.6V Flat	1

:: Reedy Chargers / Accessories**CHARGERS**

27200	1216-C2 Dual AC/DC Competition Battery Charger	1
27201	324-S AC LiPo/LiFe Compact Balance Charger	1
27201C2	324-S Charger w/3300mAh 7.4V LiPo Battery	1
27201C2	324-S Charger w/4500mAh 11.1V LiPo Battery	1
27202	123-S AC LiPo Compact Balance Charger	1
27220	7-in-1 Universal Charge Lead (4mm)	1
27221	T-plug Charge Lead (4mm)	1
27222	XH 2-6S Balance Board (4mm)	1
27223	RX Charger Lead FUT (4mm)	1
27224	US to IEC 320 C5 angle 1M AC Power Cord	1

ACCESSORIES

647	Silicone Wire 12AWG-Black (1m)	1
648	Silicone Wire 14AWG-Black (1m)	1
650	Shrink Tubing - 15pcs 4.5mm x 20mm	1
747	Silicone Wire 12AWG-Black (30m)	1
790	Silicone Wire 13AWG-Black (1m)	1
791	Silicone Wire 13AWG-Black (30m)	1

:: Reedy Electronics**SERVOS AND SERVO ACCESSORIES**

27100	RS1206 Digital HV Hi-Speed Competition Servo	1
27101	RT1508 Digital HV Hi-Torque Competition Servo	1
27102	RS1206 Servo Case Set w/screws	1
27103	RS1206 Servo Gear Set	1
27105	RT1508 Servo Gear Set	1
27111	1514MG Digital RTR Servo	1
27114	RT2406 Digital HV Brushless Competition Servo	1
27115	RT2706A Digital HV Alum. Brushless Comp. Servo	1
27130	1514MG Servo Gear Set	1
27135	RT2406 Gear Set	1
27136	RT2706A Gear Set	1
27139	RT2406 Case Set	1

SPORTS MOTOR

907	540-SL4 3300kV 4-pole Sensorless Brushless Motor	1
-----	--	---

ELECTRONIC SPEED CONTROLS

29180	SC800-BL ESC	1
29184	SC800-BL/SC1000-BL/SC1000-DB/SC600-BL Switch	1
29185	SC600-BL Brushless ESC	1
29186	SC600-BL Fan	1

:: Apparel / Promotional**TEE SHIRTS**

SP124*	AE 2017 Worlds Tee, Black (S, M, L, XL-5XL)	1
SP126*	Team Associated Tri T-Shirt, Black, (S, M, L, XL-5XL)	1
SP128*	Team Associated Womens Tri T-Shirt, Black, (S, M, L)	1
SP129*	Team Associated Youth Tri T-Shirt, Black, (S, M, L)	1
SP143*	Reedy W19 T-Shirt, Black, (S, M, L, XL-3XL)	1
SP200*	Element RC Logo T-Shirt, Gray, (S, M, L, XL-5XL)	1
SP201*	Element RC Rhombus T-Shirt, Black, (S, M, L, XL-5XL)	1

HOODIES/JACKETS

SP125*	AE 2017 Worlds Pullover, Black, (S, M, L, XL-3XL)	1
SP127*	Team Associated Tri Zip-Up, Black, (S, M, L, XL-3XL)	1
SP231*	Element RC Logo Pullover, Black, (S, M, L, XL-5XL)	1
SP142*	Reedy W19 Pullover, Black, (S, M, L, XL-3XL)	1
SP160*	Factory Team Logo Lightweight "Medal" Zip Up Streaked, Black, (S, M, L, XL-4XL)	1

HATS

SP20	AE Patch Trucker Hat	1
SP260	Element RC Hat, Curved Bill, Black	1
SP261	Element RC Hat, Flat Bill, Black	1
SP430	Reedy Trucker Hat 2018	1
SP431	Team Associated Tri Trucker Hat, Flat Bill, Black	1
SP432	Team Associated Tri Trucker Hat, Curved Bill, Black	1
SP434	Factory Team Logo Trucker Hat, Flat Bill	1
SP435	Factory Team Logo Trucker Hat, Curved Bill	1

BANNERS/MATS CARRIERS

SP115	Reedy Circuit Cloth Banner	1
SP116	Reedy Power Vinyl Banner, 48x24	1
SP117	Reedy power Cloth Banner, 96x24	1
SP118	Reedy Power Cloth Banner, 48x24	1
SP300	Team Associated Vinyl Banner, 48x24	1
SP301	Factory Team Vinyl Banner, 48x24	1
SP302	Team Associated Cloth Banner, 96x24	1
SP303	Team Associated Cloth Banner, 48x24	1
SP304	Factory Team Cloth Banner, 96x24	1
SP305	Factory Team Cloth Banner, 48x24	1
SP425	FT Fluid Carrier	1

* Use part number plus the desired size when ordering!

:: Tools

1111	FT Turnbuckle Wrench	1
1112	FT 4mm Turnbuckle Wrench	1
1114	FT Dual Turnbuckle Wrench	1
1449	Off Road Ride Height Gauge	1
1452	FT TC Ride Height Gauge	1
1498	FT Universal Tire Balancer	1
1499	FT Body Reamer	1
1500	FT 1.5mm Hex Driver	1
1501	FT 2.0mm Hex Driver	1
1502	FT 2.0mm Ball Hex Driver	1
1503	FT 2.5mm Hex Driver	1
1504	FT 2.5mm Ball Hex Driver	1
1505	FT 3.0mm Hex Driver	1
1506	FT 5.0mm Hex Driver	1
1507	FT 5.5mm Nut Driver	1
1508	FT 7.0mm Nut Driver	1
1518	FT Hex Driver Tool Set, 3pc (1.5, 2.0, 2.5)	1
1519	FT Hex/Nut Driver Tool Set, 5pc.	1
1522	FT Professional Mini Digital Scale	1
1545	FT 5/64" Blue Hex Driver	1
1555	FT Clutch Gauge, 4 Shoe	1
1568	FT 5.5mm Short Nut Driver	1
1569	FT 7mm Nut Driver, T-Handle	1
1570	FT 5.5mm Short Nut Driver	1
1571	FT 1:8 Wheel Nut Wrench, 17mm Hex	1
1579	FT Ball Cup Wrench	1
1657	FT 1/4" Hex Drive .050" Tip	1
1658	FT 1/4" Hex Drive 1/16" Tip	1
1659	FT 1/4" Hex Drive 5/64" - 2.0mm Tip	1
1660	FT 1/4" Hex Drive 3/32" Tip	1
1661	FT 1/4" Hex Drive 1.5mm Tip	1
1662	FT 1/4" Hex Drive 2.5mm Tip	1
1663	FT 1/4" Hex Drive 3/16" Nut Driver Tip	1
1664	FT 1/4" Hex Drive 1/4" Nut Driver Tip	1
1665	FT 1/4" Hex Drive 11/32" Nut Driver Tip	1
1666	FT 1/4" Hex Drive 5.5mm Nut Driver Tip	1
1667	FT 1/4" Hex Drive 7.0mm Nut Driver Tip	1
1668	FT 1/4" Hex Drive 8.0mm Nut Driver Tip	1
1669	FT 1/4" Hex Drive 5/64" - 2.0mm Ball End Tip	1
1670	FT 1/4" Hex Drive 3/32" Ball End Tip	1
1671	FT 1/4" Hex Drive Standard Screwdriver Tip	1
1672	FT 1/4" Hex Drive Phillips Screwdriver Tip	1
1674	FT 1/4" 5 Piece Power Tool Tips Set (5/64-2.0mm, 1.5mm, 2.5mm, 5/64"- 2.0mm ball, 2.5mm ball)	1
1675	FT Shock Shaft Pliers	1
1679	FT T-Handle Ratchet Driver	1
1719	FT Camber + Track Width Tool	1
1737	FT Body Scissors	1
3718	12 Inch Nylon Wire Ties	12
3987	FT Droop Gauge	1

TEAM ASSOCIATED

WORLD CHAMPION R / C CARS

Associated Electrics, Inc.
21062 Bake Parkway Lake Forest, CA 92630 USA

call: (949) 544-7500 - fax: (949) 544-7501

**Check out the following web sites for all of our kits,
current products, new releases, setup help, tips, and racing info!**
www.AssociatedElectrics.com

FOLLOW US ON SOCIAL MEDIA



TeamAssociated
ReedyPower
ElementRC



@TeamAssociatedRC
@ReedyPower
@Element_RC



@Team_Associated
@ReedyPower



AEFactoryTeam