

HOLES(4) ARE DESIGNED FOR M2.6X6mm SELF-TAPPING SCREWS USE.  
 WALL MOUNTING HOLES(2) X DIA.4.5mm FOR PAN HEAD(M4) TAPPING SCREWS USE.

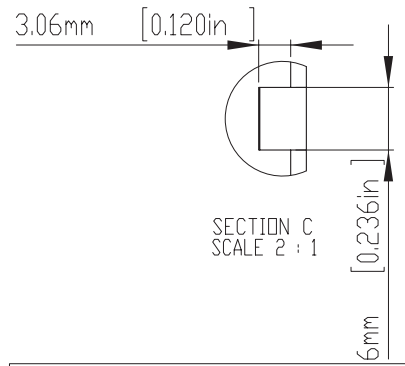
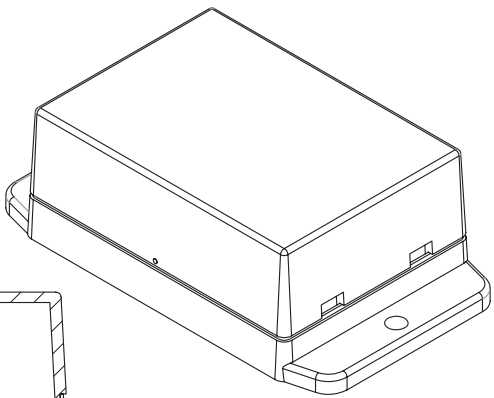
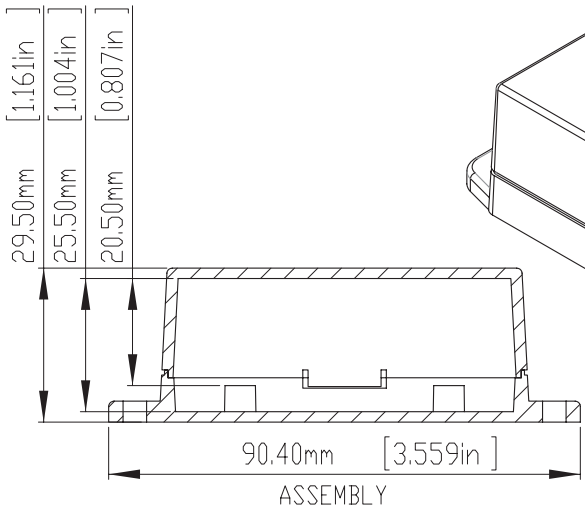
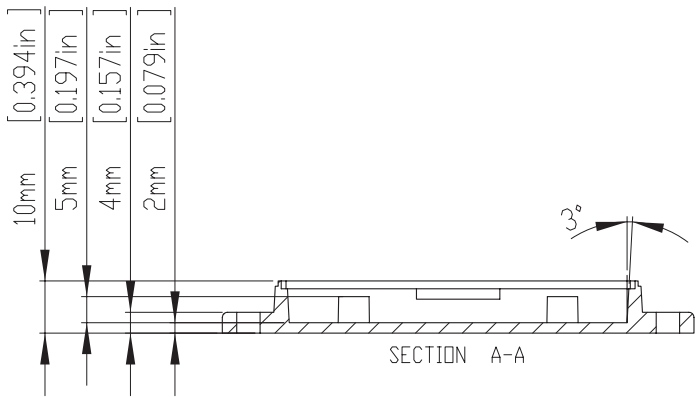
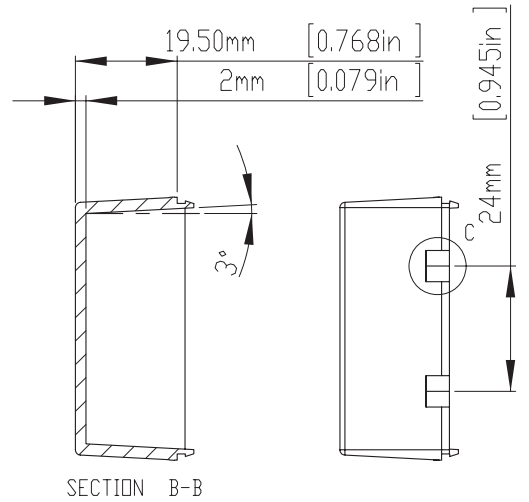
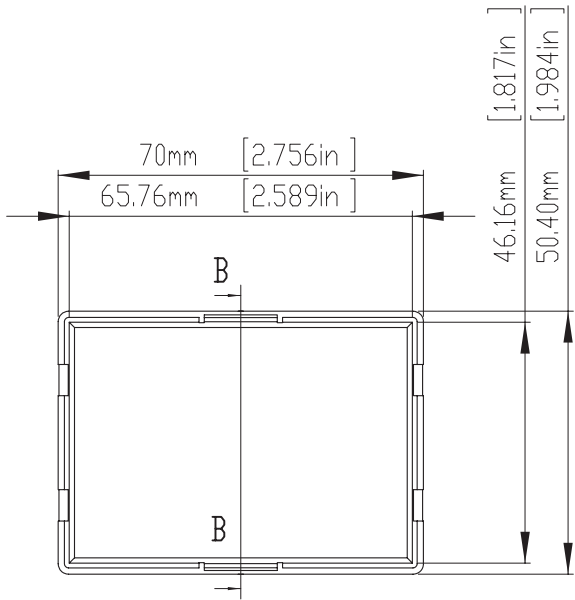

According to ISO 2768-m

Measuring DIM=L	Tolerances
0.5<L≤3.0mm	±0.1mm
3.0<L≤6.0 mm	±0.1mm
6.0<L≤30.0 mm	±0.2mm
30.0<L≤120.0 mm	±0.3mm
120.0<L≤400.0 mm	±0.5mm
400.0<L≤1000.0 mm	±0.8mm

DRA'D BY	DATE	MATE.	TITLE:	DWG NO:	REVISID:
		ABS			