

HDMI Extender over single 100m/328ft Coaxial Cables with IR Control

Operation Manual

Thank you for purchasing this product. For optimum performance and safety, please read these instructions carefully before connecting, operating or adjusting this product. Please keep this manual for future reference.

● Introduction

The HDMI Over Single Coax Extender sends HDMI signals Over just one 75Ohm Coaxial cable -- up to 100m away. The HDMI Over Single Coax Extender supports HDMI 1.3 and HDCP 1.1 with features such as Deep Color and 1080p. By using standard and widely available 75Ohm RG-6U cables, the HDMI Over Single Coax Extender makes HDMI signal extensions to be easier than heavy and expensive copper cable and more robust than optical fiber. The Extender includes two units: transmitter and receiver. The transmitting unit is used to capture the HDMI input with IR signals and carries the signals via one coaxial cable. The receiving unit is responsible for equalizing the transmitted HDMI signal and reconstructing IR and serial control signals. The Extender offers the most convenient solution for HDMI extension over a single coaxial cable with long distance capability, and is the perfect solution for any application.

● Features

1. Flexible extension of high-bandwidth HDMI 1.3 thanks to the performance and reliability of 75Ohm RG-6U Coax cable.
2. Audio and video are transmitted digitally over the 75Ohm RG-6U Coax cable with zero signal loss.
3. Single Link Range: 1080p/60, 12 bit color depth.

4. Compliant with HDMI 1.3, HDCP 1.1 standards.
5. Supports digital video formats in Deep Color Mode at up to 12bits/color.
6. Supports PCM 48KHz audio.
7. Supports Cascade function in Transmitter and Receiver and it is easy to build a network system by installer.
8. Lip-Sync Pass Through.
9. Bi-directional IR system allowing for control of source or display (IR accessories included)

● **Package Contents:**

- (1) [TX & RX]
- (2) IR Blaster (TX)
- (2) IR Receiver (RX)
- (2) DC 5V in line power supply
- (1)User Manual

● **Specification**

Frequency Bandwidth	225MHz/link (HDMI 1.3)
In/Output Support Resolution	480i, 576i, 720p@50/59.94,60 1080i@50/59.94/60 1080p@23.98/24/25/29.97/30/50/59.94/60
Input TMDS Signal:	3.3 volts
Input DDC Signal:	5.0 volts/P-P
ESD Protection Human body model	±8kV (air-gap discharge) ±4kV (contact discharge)
Coaxial Cable Distance	Full HD up to 100M (RG-6U cables)

	HD up to 200M (RG-6U cables) SD up to 300M (RG-6U cables)
Dimension (mm)	100(D)x105(W)x25(H)
Weight (g)	280
Power Supply:	(2) 5V1A DC
Power consumption:	2.3 watts (TX); 2.2 watts (RX)
Operation temperature:	32~104 °F
Storage temperature:	-4 ~140 °F
Relative humidity:	20~90 % RH (no condensation)

● Operation Controls and Functions

1. Transmitter

Front Panel

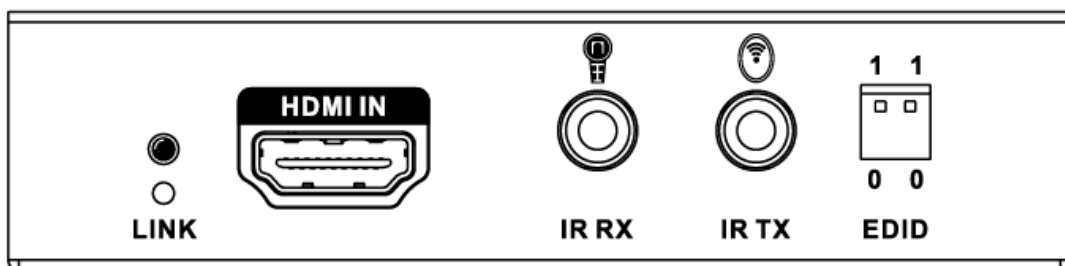

Rear Panel

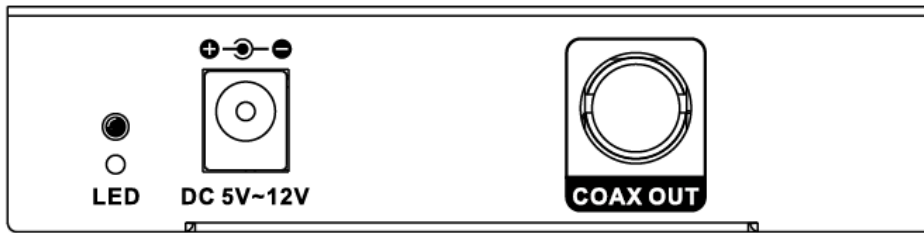

- ◆ **LINK LED:** This LED will illuminate when the device is connected with HDMI source
- ◆ **HDMI IN:** This slot is to connect with the input source equipment such as DVD or Blue-ray player with connection cable for input video and audio signal transmission.
- ◆ **IR RX:** Connect to the IR Receiver for IR signal reception. Ensure that remote being used is within the direct line-of-sight of the IR receiver.
- ◆ **IR TX:** Connect the IR Blaster cable included in the package for IR signal transmission. Place the IR blaster in direct line-of-sight of the equipment to be controlled.
- ◆ **EDID:** The EDID switch allows to pre-set an EDID to encourage a “handshake” between the display and source.

Position	EDID Description
0 0	1080p, 2CH PCM 48KHz
0 1	1080p, 5.1CH PCM 48KHz
1 0	1080p, 7.1CH PCM 48KHz
1 1	1080i, 2CH PCM 48KHz

- ◆ **Power LED:** This red LED will switch on when the device is connected with the power supply.
- ◆ **DC 5V:** Plug the 5V DC power supply into the unit and connect the adaptor to an AC outlet. The red LED will turn on when the power is on.

- ◆ **Coax Out** : Connect one 75ohm RG-6U coax cable between the transmitter and the receiver BNC port.

2. Receiver

Front Panel

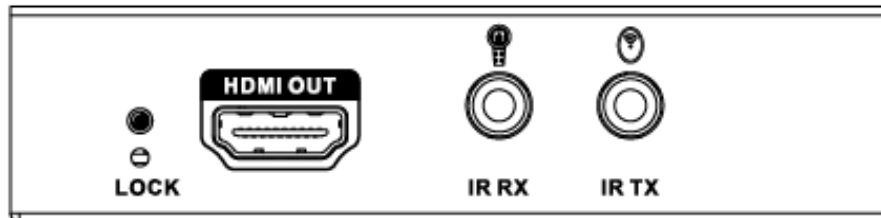

Rear Panel

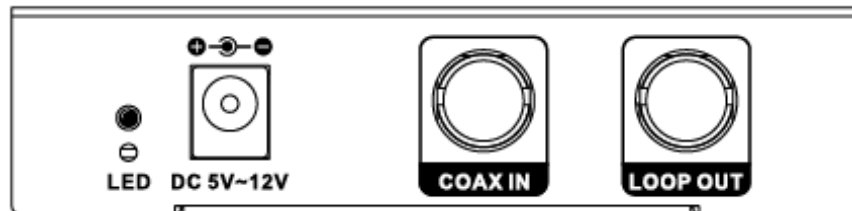

- ◆ **LOCK LED**: This LED will illuminate when the HDMI signal from the transmitter is stable.
- ◆ **HDMI Out**: This slot is where you connect a HDMI display with a HDMI cable .
- ◆ **IR RX**: Connect to the IR Receiver for IR signal reception. Ensure that remote being used is within the direct line-of-sight of the IR receiver.
- ◆ **IR TX**: Connect the IR Blaster cable included in the package for IR signal transmission. Place the IR blaster in direct line-of-sight of the equipment to be controlled.
- ◆ **Power LED**: This red LED will switch on when the device is connected with the power supply.
- ◆ **DC 5V**: Plug the 5V DC power supply into the unit and connect the adaptor to an

AC outlet. The red LED will turn on when the power is on.

- ◆ **Coax IN:** Connect one 75ohm RG-6U coax cable between the transmitter and the receiver BNC port.
- ◆ **LOOP OUT:** Connect one 75ohm RG-6U coax cable between the receiver with the next receiver BNC port.

- **Wideband IR(20KHz---60KHz) Introduction**

IR RECEIVER



IR BLASTER



IR RECEIVER (RX)

To control the source: Plug IR Receiver into IR RX port of receiver unit; place receiver at or near display.

To control the display: Plug IR Receiver into IR RX port of transmitter unit; place receiver in position where it is able to receive remote signals.

IR BLASTER (TX)

To control the source: Plug IR Blaster into IR TX port of transmitter unit; place blaster in front of the IR eye of the source.

To control the display: Plug IR Blaster into IR TX port of receiver unit; place

blaster in front of the IR eye of the display.

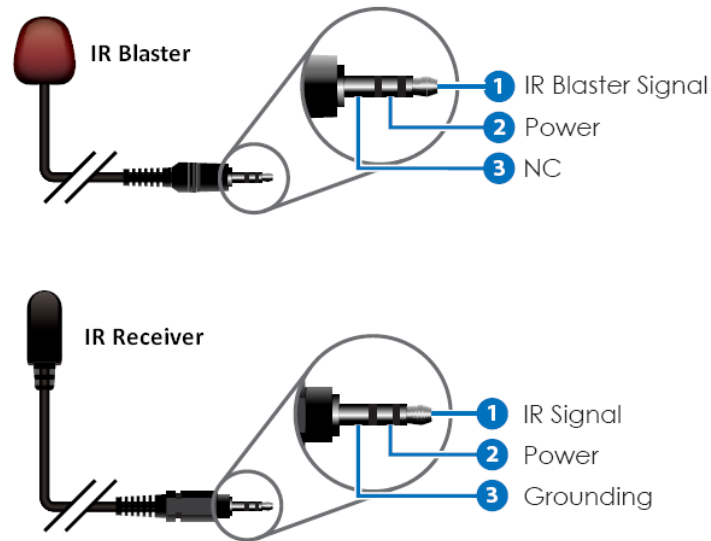

- **Connection and Installation**

Connect the HDMI Transmitter output BNC ports using single RG6 coaxial cables to included Receiver. It is strongly recommended that factory terminated cable assemblies be used and their length shall not exceed 328 ft respectively.

Connect the HDMI output from the Receiver to high-definition display devices such as HD-LCD, HD-DLP and HD projectors with HDMI input interfaces. Use high-speed HDMI cables that are recommended for the distances that are required for each connection. HDMI cable length should not exceed 16 ft.

The source can be controlled from the display. This is accomplished by using an optional IR Receiver pigtail pointing away from the display, which can be connected to the receiver portion of the extender. The IR Transmitter pigtail is then connected to the Transmitter of the extender and pointed at the source.

